

TECHNICAL MANUAL

OPERATOR'S MANUAL
FOR
CRANE, TRUCK MOUNTED
HYDRAULIC 25 TON (CCE)

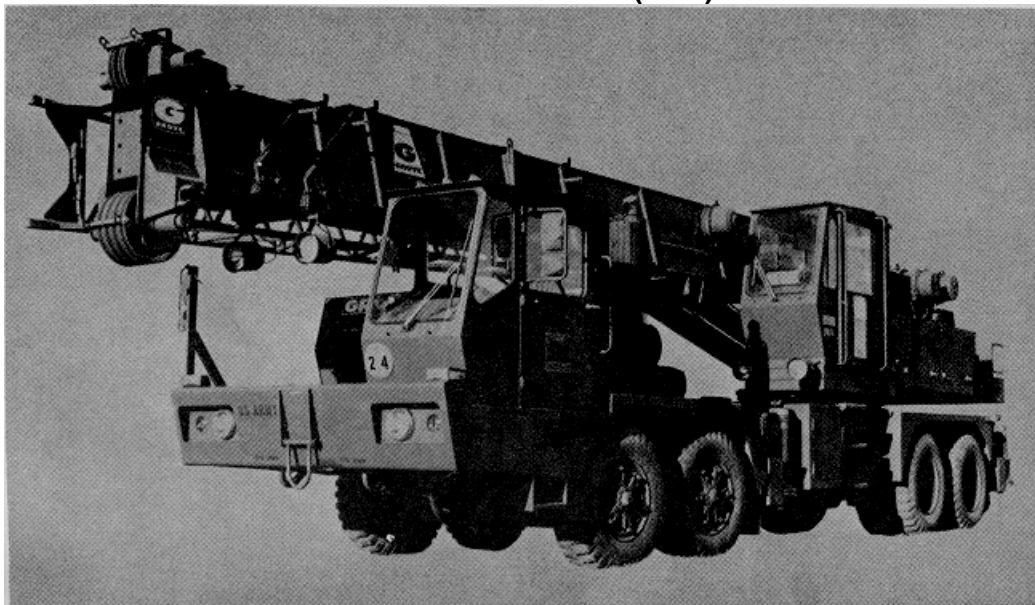

GROVE MODEL TM S-300-5
CONTRACT NO. DSA 700-77-C-8511

NSN 3810-01-054-9779

This copy is a reprint which includes current
pages from Change 2.

1 MAY 1980

WARNING

ELECTROCUTION HAZARD TO PREVENT DEATH OR SERIOUS BODILY INJURY

NEVER OPERATE THIS CRANE WITHIN ANY DISTANCE OF A POWER SOURCE OR POWER LINE WITHOUT FIRST NOTIFYING THE POWER OR UTILITY COMPANY

NEVER OPERATE CRANE, ANY PART THEREOF OR LOAD WITHIN 20 FEET OF ANY ELECTRICAL POWER LINE OR POWER SOURCE OR SUCH DISTANCE AS IS SPECIFIED OR REQUIRED BY LOCAL OR OTHER APPLICABLE SAFETY CODES OR REGULATIONS.

NEVER OPERATE CRANE WITHOUT CONSULTING LOCAL OR OTHER APPLICABLE SAFETY CODES OR REGULATIONS.

NEVER OPERATE, SERVICE, OR MAINTAIN THIS CRANE WITHOUT PROPER INSTRUCTIONS. REMEMBER, IT IS THE EMPLOYER'S RESPONSIBILITY TO IMPLEMENT THE ABOVE AND TO PROVIDE ALL SAFETY DEVICES OR MEANS THAT MAY BE NECESSARY OR REQUIRED FOR ANY USE OPERATION, SET-UP, OR SERVICE.

MAKE SAFETY FIRST---NOT LAST!!! READ YOUR OPERATOR'S HANDBOOK!

NOTE DO NOT REMOVE THIS SIGN OR OPERATOR'S MANUAL FROM THIS CRANE.

ONLY MACHINES WITH PUBLISHED "ON RUBBER" CAPACITIES ARE PERMITTED TO TRAVEL WITH A LOAD.

BEFORE ELEVATING BOOM, MAKE CERTAIN THAT AREA ABOVE AND BENEATH BOOM IS CLEAR OF ALL OBSTRUCTIONS AND PERSONNEL.

BEFORE LOWERING BOOM, MAKE CERTAIN AREA BENEATH BOOM IS CLEAR OF ALL OBSTRUCTIONS AND PERSONNEL.

BEFORE LOWERING OR RAISING CABLE (LOAD) ASSURE THAT AREA BENEATH LOAD IS CLEAR OF ALL OBSTRUCTIONS AND PERSONNEL.

Information in this manual does not replace federal, state, or local regulations, safety codes, or insurance requirements.

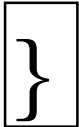
CHANGE
NO. 2HEADQUARTERS
DEPARTMENT OF THE ARMY
WASHINGTON, DC, 19 July 1984

TECHNICAL MANUAL
OPERATOR'S MANUAL
FOR
CRANE, TRUCK MOUNTED
HYDRAULIC 25 TON (CCE)
GROVE MODEL TM S300-5
NSN 3810-01-054-9779

TM 53810-300-10, 1 May 1980, is changed as follows:

Inside front cover, in front of page 1. The following warnings are added:

WARNING

Outriggers must be extended and set anytime the boom is removed from the cradle, either lifting or positioning. Outriggers may be retracted from "ON RUBBER" operation with the boom centered over the rear as indicated by the "ON RUBBER" load chart. (Outriggers must be extended and set to place the boom in the "ON RUBBER" position.)

Page 7, Part L Line 5 change word, Pulling to Pushing.

Page 29, Part L After the phrase, Stop Trouble Before It Stops You!
add the following:

WARNING

PASSENGERS: Passengers are not authorized to ride in the crane cab to and from work sites. The crane operator may be permitted to ride. in the cab for short distances where very light loads are being relocated, provided these loads are within the limits of operation without outriggers. These limits are specified on the load and boom angle charts located inside the crane cab.

Page 1, Part IL After line 8 add the following:

WARNING

Outriggers must be extended and set anytime the boom is removed from the cradle, either lifting or positioning. Outriggers may be retracted from "ON RUBBER" operation with the boom centered over the rear as indicated by the "ON RUBBER" load chart. (Outriggers must be extended and set to place the boom in the "ON RUBBER" position.)

*This change supersedes C1, 13 August 1982.

Page 6, Part II. Add the following between pages 6 and 7:

**TMS300
RATED LIFTING CAPACITIES IN POUNDS-ON RUBBER
33 ft - 80 ft (10.0 m - 24.2 m)
3 SECTION BOOM WITH CT. WT.**

LIFTING CAPACITY NOTES

1. Capacities appearing above bold line are based on structural strength and tipping should not be relied upon as a capacity limitation.
2. All lifting depends on proper tire inflation, capacity and condition. Rated loads are based on 11.00 x 20 (12 Ply) bias rear tires and 85 psi cold inflation pressure. Loads must be reduced for lower inflation pressures.
3. Capacities not applicable to machines equipped with Michelin 11.00 x 20 X-G (14 PR) ZZ or any radial rear tires.
4. Capacities are applicable with the machine on a firm level surface only.
5. 32' (9.8 Meter) boom extension not permitted for on rubber lifts.
6. For 2.5 MPH (4 Km/h) pick and carry operation, boom must be centered over rear of machine and mechanical swing lock engaged.

**TMS300 - (33' - 80') 3-SECT. BOOM, WITH CT. WT.
LIFTING CAPACITIES (POUNDS)-ON RUBBER**

RADIUS IN FEET	STATIONARY CAPACITY BOOM CENTERED OVER REAR	2.5 MPH CAPACITY BOOM CENTERED (6) OVER REAR
15	28,480 (a)	17,020 (a)
20	19,080 (a)	13,880 (a)
25	13,310 (b)	11,170 (a)
30	9,550 (c)	8,870 (b)
35	7,310 (c)	6,600 (c)
40	5,710 (d)	4,980 (c)
45	4,420 (e)	3,680 (d)

MAXIMUM PERMISSIBLE BOOM LENGTH:

- (a) 33 FT.
- (b) 38 FT.
- (c) 44 FT.
- (d) 50 FT.
- (e) 56 FT.

Page 10, Part II. After line 8 add the following:

CAUTION

Only diesel pile driven hammers shall be attached and utilized with this crane. Instructions for set-up and operation are contained in TM 5-3895-265-14.

Page 10, Part II. The following illustrations are added between pages 10 and 11:

- a. Hook Block Reeving Information, TA 193001
- b. Boom Reeving Clamshell Operation, TA 221986

HOOK BLOCK

Reeving of the hook block will be accomplished according to the following information:

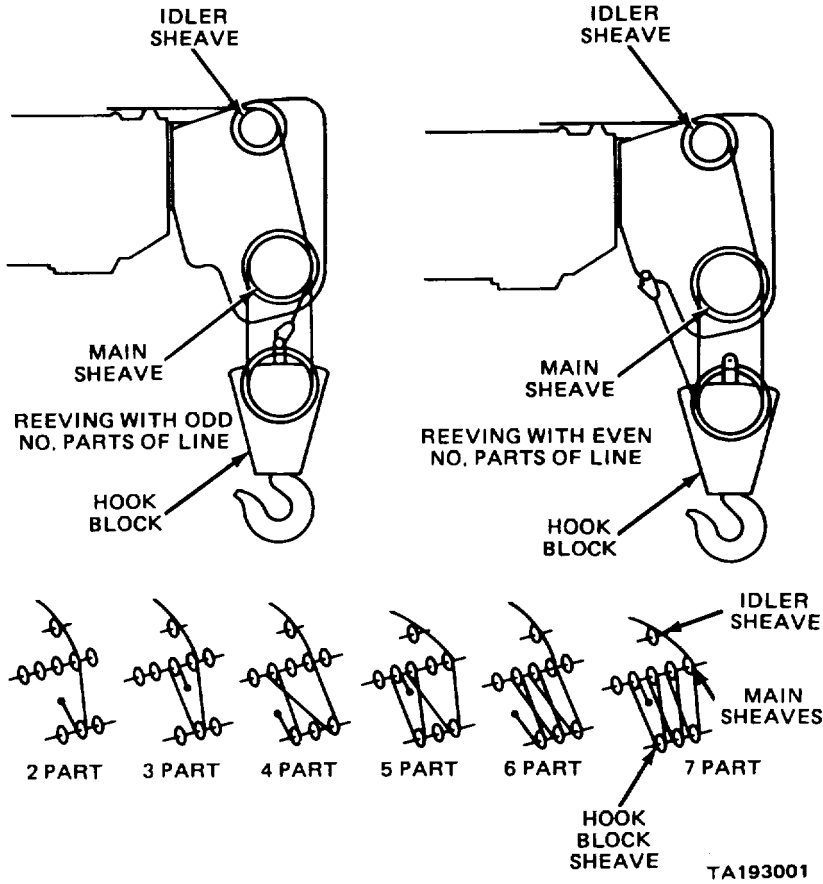

HOOK BLOCK REEVING INFORMATION

CLAMSHELL

Reeving shall be accomplished as per instructions in commercial manual of the clamshell bucket being utilized since clamshell buckets differ between manufacturers. Use the following for reeving of crane boom.

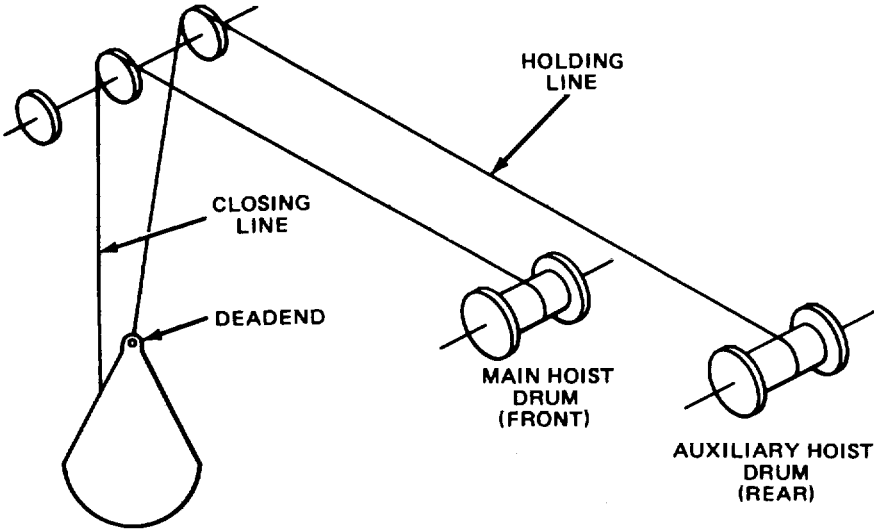

TA221986

BOOM REEVING FOR CLAMSHELL OPERATION

CAUTION

Proper utilization of clamshell shall be accomplished as per instructions in commercial manual of the clamshell bucket being utilized.

Page 40, Part 1. Lubrication Chart is superseded by the following:

ITEM NO.	LUBE POINTS	LUBRICANT SYMBOL	FREQUENCY OF LUBRICATION
1	Engine Crankcase	EO/HDO	1,000 miles
2	Engine Oil Filter	Replace	1,000 miles
3	Crankcase Breather	Check and Clean	1,000 miles
4	Alternator	EO/HDO	1,000 miles
5	Water Pump	WPG	1,000 miles
6	Deleted		
7	Accelerator Linkage	EO/HDO	1,000 miles
8	Air Cleaner	Clean or Replace	1,000 miles
9	Clutch Pedal Shaft	CG	1,000 miles
10	Clutch Release Bearing	CG	1,000 miles
11	Gear Shift Control	CG	1,000 miles
12	Clutch Cross Shaft	CG	1,000 miles
13	Transmission	GO	1,000 miles
14	Drive Shaft Support Bearings	CG	1,000 miles
15	Speedometer Cable	EO/HDO	10,000 miles
16	Tachometer Cable	EO/HDO	10,000 miles
17	Equalizer Beam Center Pins	CG	1,000 miles
18	Equalizer Boom End Pins	CG	1,000 miles
19	Drive Shaft Universals	CG	1,000 miles
20	Drive Shaft SlipJoints	CG	1,000 miles
21	Steering Gear Housing	GL	1,000 miles
22	Tie-Rod Ball Joints	CG	1,000 miles
23	Steering Knuckles	CG	1,000 miles
24	Front Wheel Bearings	WBG	10,000 miles
25	Drag-Link U-Joint	CG	1,000 miles
26	Drag-Link Ends	CG	1,000 miles
27	Rear Axle Differential	GO	1,000 miles
28	Hydraulic Pump Gear Box	GO	1,000 miles
29	PTO Shaft to constant speed pump two universal joints	CG	200 hours

LUBRICANT CODE

EO/HDO - Engine Oil

GO - Gear Oil SAE 90, Summer

SAE 80, Winter

BG - Ball & Roller Bearing Grease

CG - Chassis Grease

EPG - Extreme Pressure Grease

WBG - Wheel Bearing Grease

MPG - Multi-Purpose Grease

*Reference should be made to the Lubricant Recommendation Section of this manual. Specific oil and grease as recommended by component manufactures are always highly desirable, however, multi-purpose grease usually has qualities that meet requirements of a variety of single- purpose greases. Consult your supplier for recommendations.

Page 41, Part I. Illustration is superseded by the following:

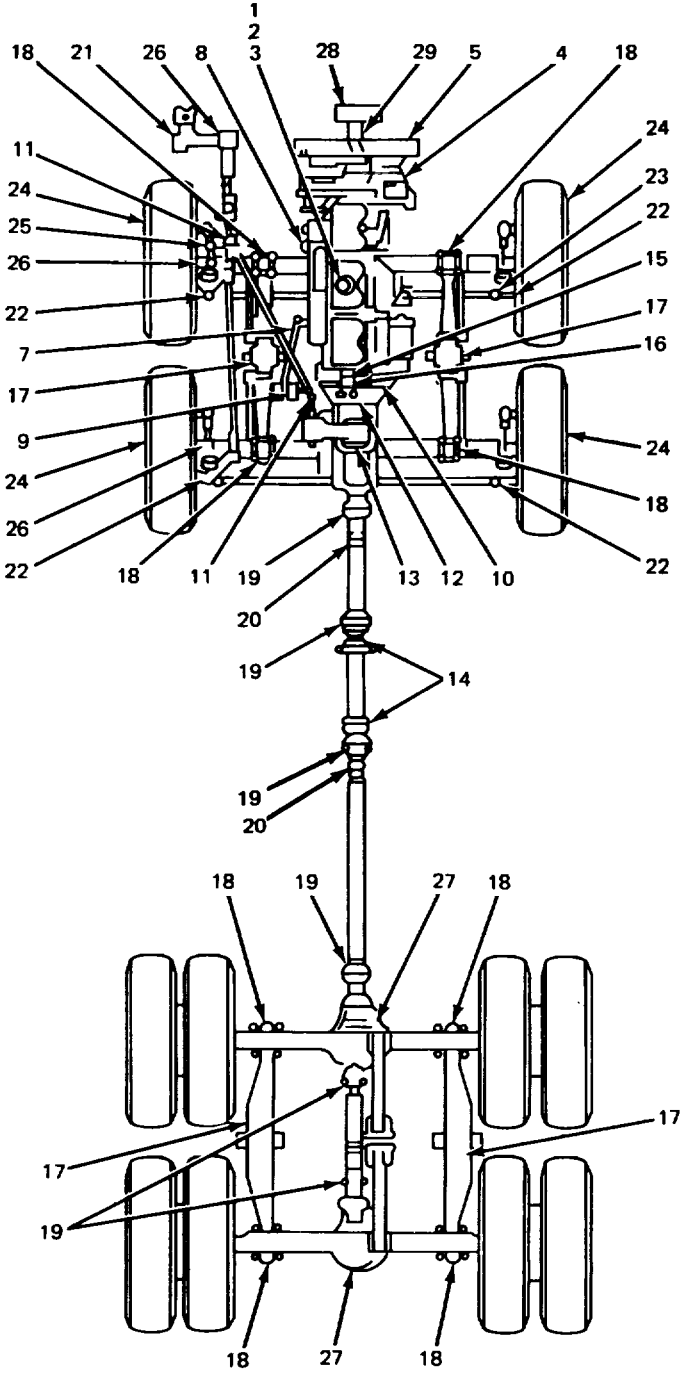

TA221987

Page 7, Part II. Line 8 change from 25 Ton, 4 Sheave
-585 lbs. to 25 Ton, 4 Sheave -590 lbs.

Page 7, Part II. After line 13 add the following:

Tag Winder - 275 lbs.
Clamshell - 3200 lbs.

By Order of the Secretary of the Army:

JOHN A. WICKHAM, JR.
General, United States Army
Chief of Staff

Official:

ROBERT M. JOYCE
Major General, United States Army
The Adjutant General

DISTRIBUTION:

To be distributed in accordance with DA Form 12-25B, Operator Maintenance Requirements for Cranes,
Truck Mounted.

PART I



**OPERATORS
HANDBOOK**

**TMS-300-5
CARRIER**

CONTRACT NO. DSA 700-77-C-8511

FEBRUARY 1978



*This manual contains copyright material.
Published through the courtesy of Lipe-Rollway Corp.,
Syracuse, NY, and Rockwell International, Automotive
Operations, Troy, Michigan.*

TECHNICAL MANUAL

HEADQUARTERS

No. 5-3810-300-10

DEPARTMENT OF THE ARMY
Washington, D.C., 1 May 1980

**OPERATOR'S MANUAL
CRANE, TRUCK MOUNTED, HYDRAULIC
25 TON (CCE)**

**GROVE MODEL TM S-300-5
CONTRACT NO. DSA 700-77-C-8511
NSN 3810-01-054-9779**

REPORTING OF ERRORS

You can help improve this manual by calling attention to errors and by recommending improvements and by stating your reasons for the recommendations. Your letter or DA Form 2028 (Recommended Changes to Publications and Blank Forms) should be mailed directly to Commander, US Army Tank-Automotive Materiel Readiness Command, ATTN: DRSTA-MBS, Warren, MI 48090. A reply will be furnished direct to you. DA Form 2028-2 is included in the back of this manual.

CONTENTS

PART I.	CARRIER	
PART II.	SUPERSTRUCTURE	
PART III.	KRUGER LOAD MOMENT SYSTEM.	

This technical manual is an authentication of the manufacturers' commercial literature and does not conform with the format and content specified in AR 310-3, Military Publications. This technical manual does, however, contain available information that is essential to the operation and maintenance of the equipment.

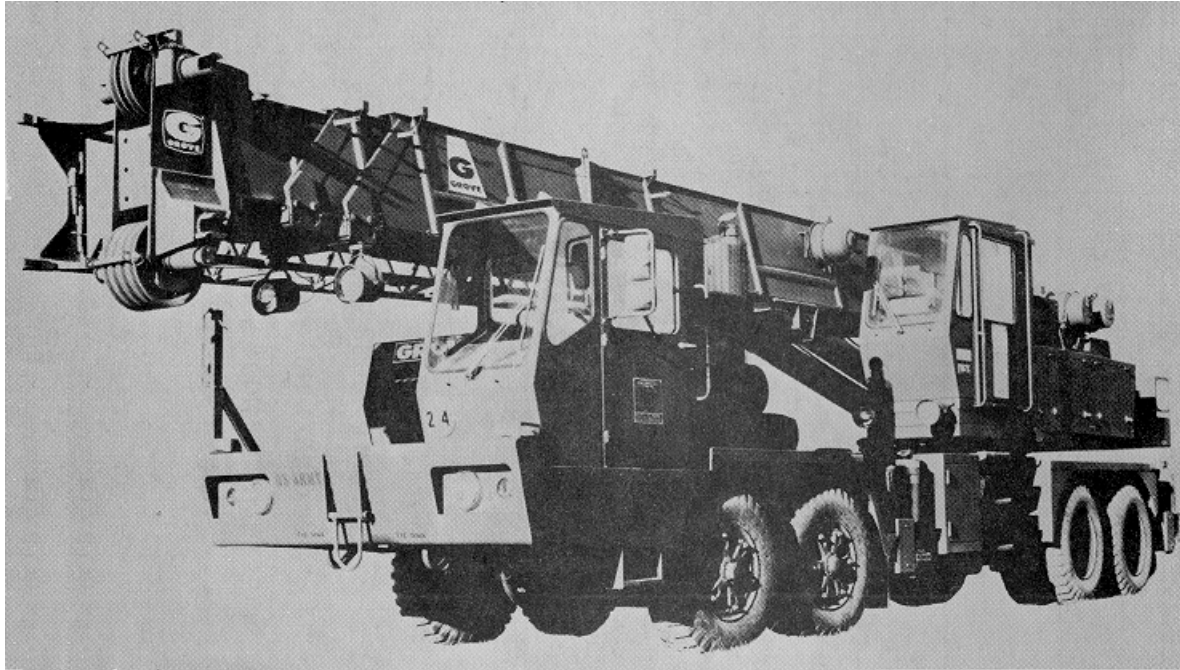

**STOP !
read this**



FOREWORD

This manual has been compiled as a guide to proper Operation and routine Maintenance of your Grove carrier. Even though the operator may be experienced, thorough familiarization with each unit is imperative to avoid those unforeseen emergencies that could prove to be disastrous. Just reading the manual or casually looking at the carrier is not enough. Study the two together.

Manuals covering major components such as engine, transmission, etc., are supplied for detailed operation, maintenance and overhaul procedures and should be referred to for specific information on those items.

Preventive maintenance and lubrication schedules should be established to assure efficient operation and to prevent unnecessary wear and costly breakdown.

In compliance with the Federal Clean Air Act, a required Owner's Emission Control Maintenance Service Chart and Guide is included in the Appendix Section of this manual.

This page intentionally left blank.

TABLE OF CONTENTS

FOREWORD
"BREAKING IN" A NEW CARRIER

SECTION I.
DESCRIPTION
and
OPERATING INFORMATION

SUBJECT	PAGE NO.
INSTRUMENTS AND CONTROLS	3
OPERATING INSTRUCTIONS	8
Pre-Starting Checks	8
Safety Checks	8
Before Starting	8
Starting Engine	9
Aid to Cold Weather Starting.	9
Idling Engine	10
Racing engine	10
Engine Shutdown	11
Emergency Stop Knob	11
Clutch Operation	12
Shifting Gears	12
Operating on Grades	13
Transmission Systems	14
Transmission Operation - RT0613.....	15
Air Brake System	21
Brake Operation	21
Inter-Axle Differential Lock.....	24
Engine Power Take-Off	25
BEFORE OPERATION	26
GOOD DRIVING HABITS	28

TABLE OF CONTENTS

**SECTION II.
FUEL
and
LUBRICANTS**

SUBJECT	PAGE NO.
DIESEL ENGINE FUEL OIL.....	31
DIESEL ENGINE LUBRICATING OIL.....	33
Oil Quality.....	33
Mil-L-2104C Lubricants.....	33
Mil-L-46167 Lubricant	34
Multigrade Oils	34
Cold Weather Operation	34
Oil Changes	34
Oil Filtration.....	35
LUBRICANT RECOMMENDATIONS.....	36
Drive Gear Lubricants	36
Wheel Bearing Grease	36
chassis Grease	36
Power Steering Fluid.....	37
Transmission Lubricants	37
Clutch Release Bearing Lubricant	37
LUBRICATION CHART	38
CAPACITY CHART	39
CHASSIS LUBRICATION	40

**SECTION III.
SERVICING
and
PREVENTIVE MAINTENANCE**

SUBJECT	PAGE NO.
SERVICING AND PREVENTIVE MAINTENANCE CHART	43
SERVICING AND PREVENTIVE MAINTENANCE	44
Engine Oil and Filter	44
Coolant.....	44
Hoses	45
Radiator	45
Fuel	45

TABLE OF CONTENTS

SUBJECT	PAGE NO.
Fuel Strainer	45
Air Cleaner	45
Air Box	46
Blower	46
Starting Motor	46
Alternator	46
Battery	47
Tachometer Drive	47
Throttle Control	47
Belts	47
Fan	47
Engine Tune-Up	48
Clutch	48
Transmissions	49
Drive Axles	49
Universal Joints	49
Front Axles and Steering Gear	49
Wheel Bearings	50
Brake System	50
Wheels and Tires	50
TIRE LOADING AND PRESSURE CHART	51

**SECTION IV.
TROUBLESHOOTING GUIDE**

SUBJECT	PAGE NO.
FOREWORD	53
TROUBLESHOOTING DIESEL ENGINES	54
CLUTCH	58
TRANSMISSION	58
PROPELLER SHAFT	59
AIR BRAKES	59
FRONT AXLE AND STEERING	61
TIRES	61

TABLE OF CONTENTS

**SECTION V.
APPENDIX**

SUBJECT	PAGE NO.
EXPLANATION OF REQUIRED EMISSION CONTROL MAINTENANCE SERVICES.....	64
SYMPTOMS OF MALFUNCTIONS WHICH MAY AFFECT ENGINE EMISSIONS.....	67
REQUIRED OWNER'S EMISSION CONTROL MAINTENANCE SERVICE CHART.....	68
POWER STEERING SCHEMATIC.....	69
AIRCRAFT ONLOADING PROCEDURE.....	70

**SECTION VI.
ADDENDUM**

ENVIRONMENTAL PROTECTION AGENCY PROVISIONS.....	72
---	----

"BREAKING-IN" A NEW CARRIER

Your new Grove carrier has been thoroughly tested, adjusted, lubricated and inspected prior to delivery. However, as road shock, crane operation, moving parts "wear in" or gasket and hose connections "take a set" an occasional oil, air or coolant leak may develop. Immediate corrective action should be taken to avoid major repairs later. For detailed engine "break-in", reference should be made to the applicable Engine Operator's Manual.

As a "rule of thumb", 2,000 3,000 miles may be considered the equivalent of 100 hours which should also be considered the "break-in" period.

Some important rules to follow to establish conditions for long service life are:

1. Operate as much as possible in half to three-quarter throttle or load range.
2. Avoid long periods of operation at engine idle speeds or at continuous maximum horsepower levels.
3. Develop the habit of observing instruments often and shut down at first indication of abnormal readings.
4. Operate to a power requirement that allows acceleration to governed speed when conditions require more power.
5. Check all components frequently for proper operation, unusual noises or excessive heating.
6. Check engine oil and coolant levels frequently.

These rules should not be considered as limitations in putting your equipment to work at maximum capability but rather to serve as a guide to familiarization and development of good operating habits.

This page intentionally left blank.

TABLE OF CONTENTS

**SECTION I.
DESCRIPTION
and
OPERATING INFORMATION**

SUBJECT	PAGE NO.
INSTRUMENTS AND CONTROLS	3
OPERATING INSTRUCTIONS	8
Pre-Starting Checks	8
Safety Checks	8
Before Starting Engine	8
Starting Engine	9
Aid to Cold Weather Starting	9
Idling Engine	10
Racing engine	10
Engine Shutdown	11
Emergency Stop Knob	11
Clutch Operation	12
Shifting Gears	12
Operating on Grades	13
Transmission Systems	14
Transmission Operation - RT0613	15
Air Brake System	21
Brake Operation	21
Inter-Axle Differential Lock	24
Engine Power Take-Off	25
BEFORE OPERATION	26
GOOD DRIVING HABITS	28

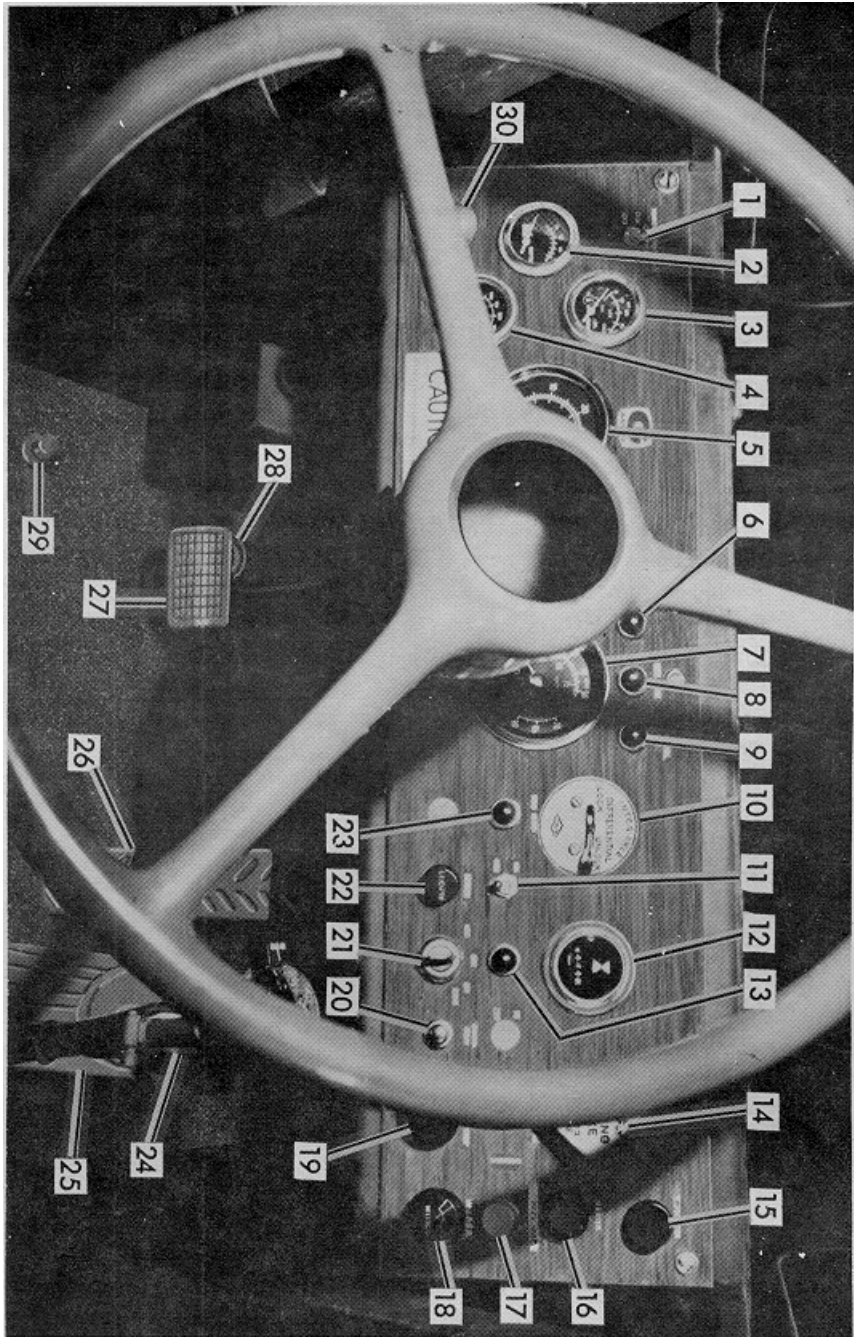

CONTROLS, GAGES AND INDICATORS

The items that follow identify the controls, gages, and indicators in the Carrier Cab. Also, the paragraphs specify the purpose of each control, indicator, and gage. The index numbers on the illustration correspond to the numbers in the paragraphs.

1. **REMOTE THROTTLE CONTROL.** Controls operation of the Superstructure throttle. When in the ON position allows the Superstructure air throttle system to control engine rpm.
2. **VOLTMETER.** Indicates the battery condition, when alternator is not producing electromotive force (volts). Also, shows condition of the charging system when engine is operating.
3. **ENGINE OIL PRESSURE GAGE.** Normal operating pressures should remain in a range of 40 to 60 psi.
4. **ENGINE WATER TEMPERATURE GAGE.** Normal temperature indication should be in the range of 170" to 185 F. If temperature indication is abnormal, operation of automatic radiator shutters and/or the thermostat should be checked.
5. **ENGINE TACHOMETER.** Indicates revolutions per minute at which engine is operating.

MAIN AIR SYSTEM PRESSURE GAGE. (Not Shown). Indicates pressure in main air tank. Operating range is normally between 95 and 125 psi. If pressure drops below 75 psi, a low pressure warning buzzer will operate and the red warning light will illuminate.

FUEL GAGE. (Not Shown). Indicates fuel tank quantity in fractions of the total tank capacity.

6. **LOW AIR PRESSURE WARNING LIGHT.** This light activates simultaneously with the warning buzzer. If traveling, immediate stop should be made to avoid automatic application of spring brakes.
7. **SPEEDOMETER AND ODOMETER.** Indicates road speed and total mileage vehicle has traveled.
8. **LIGHT BEAM INDICATOR LIGHT.** Indicates whether lights are on **LOW** or **HIGH** beam.
9. **DIFFERENTIAL LOCK INDICATOR LIGHT.** Indicates when the inter-axle differential control is in the **LOCK** position.
10. **INTER-AXLE DIFFERENTIAL CONTROL LEVER.** When positioned to **LOCK** engages (**LOCK OUT**) the inter-axle differential.
11. **CAB LIGHT SWITCH.** Controls overhead light.
12. **HOURLMETER.** Provides a digital readout of engine operating hours. Controlled by a pressure switch in the engine oil system.
13. **IGNITION ON INDICATOR LIGHT.** Indicates that the ignition switch is positioned to ON or ACC.
14. **PUSH-PULL PARKING BRAKE CONTROL.** Pulling control button out releases air in the spring loaded automatic brake units on the rear tandem axles. Pushing button in compresses the springs, releasing the brakes. Do NOT use to stop vehicle except in an emergency as a severe sudden stop will occur.
15. **DEFROSTER PUSH-PULL CONTROL.** Pulling the control allows air from the heater to flow to the windshield for defrost. Pushing the control allows air to flow out of the heater vents into the cab.

16. **CAB HEATER FAN CONTROL.** Variable speed control adjusts air output as desired.
17. **HEAT PUSH-PULL CONTROL.** Pulling the control opens a valve in the heater inlet water line to control the temperature of the air.
18. **WINDSHIELD WIPER SWITCH.** This switch has three positions OFF LOW HIGH with built-in circuit breaker.

PARKING BRAKE WARNING LIGHT. (Not Shown). When RED, indicates parking brake is "on".

19. **ENGINE EMERGENCY STOP CONTROL.** Used only when engine does not stop with normal
20. **ENGINE STOP BUTTON.** Depressing button energizes a solenoid valve which places the injector racks in the "no fuel" position.
21. **IGNITION SWITCH.** Provides for controlling electrical power to the Carrier and for starting the engine.
22. **LIGHTS SWITCH.** Three position switch controls parking marker lights, head-tail lights, and indirect instrument panel lights.
23. **HYDRAULIC PUMP INDICATOR LIGHT.** Indicates if the hydraulic pumps constant speed drive is engaged or disengaged.
24. **ROADRANGER GEAR SHIFT LEVER.** Shift pattern shown on decal.

GEAR RANGE SELECTOR VALVE. (Not Shown). Range positions shown on shift lever knob and decal.

COUNTERSHAFT BRAKE CONTROL BUTTON. (Not Shown). Used only to assist initial engagement when vehicle is standing still.

25. **ACCELERATOR PEDAL.** Controls engine speed by mechanical linkage to the governor control shaft. Depress to increase engine speed.
26. **AIR BRAKE PEDAL.** Controls air valve in line from air system tank to wheel air brakes. Because of light force required to actuate pedal, extreme care should be taken during initial familiarization.
27. **CLUTCH PEDAL.** Hydraulic master and slave system provides easier clutch operation. First 1 1/2 inches of free pedal travel provides clutch release bearing clearance.
28. **WINDSHIELD WASHER CONTROL.** Bulb type located to the left of the clutch pedal. Non-freezing type windshield washer fluid should be used at all times.
29. **HIGH-LOW BEAM LIGHT SWITCH.** Conventional foot button type with high beam indicator on panel.
30. **DIRECTIONAL SIGNAL SWITCH.** Push lever up for right turn indication and pull down for left indication. Lever will automatically return to neutral when wheels are straightened out after turn.

QUICK START BUTTON. (Not Shown). Can only be energized while starter is held in "on" position.

HAZARD LIGHT SWITCH. (Not Shown). Move switch forward to actuate four-way flasher when required. Move switch backward for OFF.

TURN SIGNAL INDICATOR. (Not Shown). Blinking light indicates turn switch is in signal position and signal lights are working properly.

CONSTANT SPEED PUMP DRIVE DISCONNECT HANDLE. (Not Shown). Pulling handle disengages the constant speed pump drive.

OPERATING INSTRUCTIONS

PRE-STARTING CHECKS

Before starting each day, check or inspect as follows to assure trouble-free performance:

1. Be sure oil level is at, or close to, the FULL mark. Do not overfill. If it is necessary to add lube oil, specify the same grade and brand as that already in the crankcase. Do NOT mix oils.
2. Maintain the coolant level near the top of the radiator or surge tank.
3. Check the ground below the vehicle for signs of leaks. If noted, check hoses and lines for leaks. Be sure condition causing leak is corrected before starting out.
4. Check level of fuel in the tank and make sure gage is reading correctly. Drain a small amount of fuel from the fuel strainer to remove any water or contaminants that may have settled in the bottom.

SAFETY CHECKS

Equally important as the pre-starting checks, is a complete safety check of your vehicle:

1. Make a check of safety equipment, including all lights, windshield wipers, washers, washer liquid supply, horn, instruments, air pressure, all brakes, signaling devices, etc.
2. Check tires before you start.
3. Check clutch pedal by hand for "free travel".
4. If PTO operation is to be used, check for proper operation and signal system indication.
5. Adjust seat and mirrors for clear vision and safe driving.

BEFORE STARTING ENGINE

Set Parking Brake, Depress clutch pedal and check gear shift levers and PTO for neutral position. Make sure EMERGENCY STOP and air valve on the air box (if it was used to stop the engine) are in run position.

STARTING ENGINE

Depress clutch pedal fully and accelerator about half-way. Engage starter, releasing it as soon as engine has started. Keep clutch depressed until engine runs smoothly. After engine has started, run it at approximately 1000 RPM. If oil pressure is not indicated within 10-15 seconds, make immediate shutdown, and check lubrication system. High oil pressure at start-up is not cause for concern. If engine is maintaining oil pressure and the other systems that should be functioning appear normal, continue to run engine at approximately 1000 RPM until coolant temperature is at 140° F or above. Do not race engine for faster warmup.

When water temperature is too low, the cylinder walls retard heating of air during compression and delays ignition. This causes incomplete combustion detonation, excessive exhaust smoke and high fuel consumption.

If engine does not start within 30 seconds, allow starting motor to cool and battery to recover for a minute or two before trying again.

After warmup, the engine should come up to normal operating temperature after driving or operating the crane. Under normal conditions, oil pressure should remain in a range of 40 to 60 pounds. Coolant temperature should be in the range of 170° to 185° F.

AID TO COLD WEATHER STARTING

The correct grade of oil for the prevailing ambient temperature should be used in the crankcase to prevent hard cranking. The diesel fuel should have a pour point of 10°F less than the lowest expected temperature. In case of emergency, white kerosene may be added to the fuel to bring the pour point down to the required temperature in order to prevent clogging of filters and small passages by wax crystals. The addition of kerosene is NOT recommended for general use.

If low temperatures are ONLY expected at start-up, it is advisable to use starting aids such as preheating, ether compound metering equipment or ether spray application into the air cleaner intake.

When it is necessary to use the "QUICK START" installation to start engine, turn switch to START, and push the "QUICK START" button down for one or two seconds and release. If engine does not start before 30 seconds, allow starter to cool a minute or two and repeat procedure.

CAUTION : AVOID OVERLOADING THE INTAKE SYSTEM WITH HIGH VOLATILE FLUID WHICH COULD RESULT IN A MINOR EXPLOSION.

Detailed recommendations for cold weather starting and operation are covered in specific sections of your applicable engine manual.

IDLING ENGINE

Idling engine unnecessarily for long periods of time wastes fuel and fouls injector nozzles. Unburned fuel causes carbon formation, oil dilution, formation of lacquer or gummy deposits on the valves, pistons and rings and rapid accumulation of sludge in the engine.

NOTE : WHEN PROLONGED ENGINE IDLING IS NECESSARY, MAINTAIN AT LEAST 800 RPM.

RACING ENGINE

NEVER race engine during warm-up period. NEVER operate engine beyond governed speed (as might occur in downhill operation or downshifting). Engine bearings, pistons and valves may be damaged if these precautions are not taken.

ENGINE SHUTDOWN

It is important in a normal shutdown that the engine be idled under no load conditions at half-speed or less for at least three to five minutes. This allows lubricating oil and coolant to carry heat away from the combustion chamber, pistons, valves and exhaust system. Sudden shutdown results in extreme localized heat-rise with potential engine damage.

Shutdown is accomplished by PRESSING THE STOP BUTTON and holding it until engine stops.

EMERGENCY STOP KNOB

In an emergency, or if after pushing the engine stop button the engine continues to operate, the emergency stop knob may be pulled to stop the engine. This knob, when pulled, will trip the air shutdown valve located between the air inlet housing and the blower and shut off the air supply to the engine. Lack of air will prevent further combustion of the fuel and stop the engine.

The emergency stop knob must be pushed back in after the engine stops so the air shutdown valve can be manually reset for restarting. The reset lever must be pushed toward a horizontal position to reset the air shutdown valve.

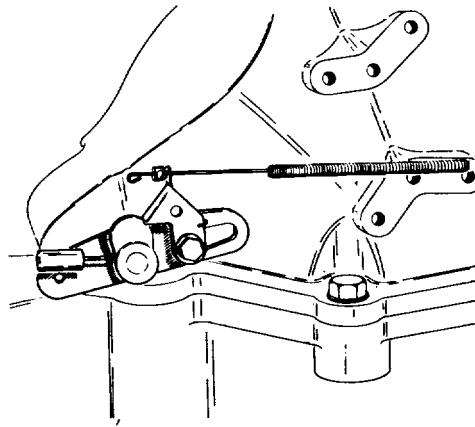

CLUTCH OPERATION

Clutch pedal travel adjustment provides for approximately 1 1/2 inches of downward movement of the pedal before engaging the release bearing. It is important that this travel be maintained to avoid possible excessive wear on this bearing and/or clutch slippage. **IMPORTANT:** NEVER ALLOW FOOT TO "RIDE" THE CLUTCH PEDAL WHEN CLUTCH IS ENGAGED THIS CAUSES PREMATURE RELEASE BEARING FAILURE AND SHORT CLUTCH FACING LIFE.

"Double-clutching" is a means of bringing the speed of transmission gears into synchronization so that the shift can be made without clash. The engine is used to speed up the countershaft for a downshift and to slow it down for an upshift. "Doubleclutching" operation is accomplished as follows:

1. Depress clutch pedal and shift to neutral.
2. Release clutch pedal and accelerate engine (when making downshift) or allow engine to slow down (when upshifting) until engine speed approximately corresponds to road speed of gear ratio selected.
3. Depress clutch pedal and complete shift.

SHIFTING GEARS

Next to concern for safety, good shifting habits are probably the most important capability a driver can have. Knowing how and when to shift can return savings in trip time and operating expense.

In the early stage of moving the vehicle, keep the engine speed down to the actual power requirement but anticipate the next shift demand and do not cause the engine to labor with the next shift. Start the vehicle in the lowest gear available and with the first few shifts, develop only the RPM needed to get rolling. Then as you upshift, increase vehicle speed in each gear with a progressive increase in engine speed. It should seldom be necessary to go to

governed engine speed in the lower gears except in a peak load situation such as starting up a grade.

When driving conditions permit, maintain the desired road speed in a gear that permits running the engine preferably 15 to 20 percent below governed speed to allow engine to accelerate to or to maintain governed RPM when applying full throttle. In this cruise range, the engine affords better fuel economy than at higher speeds.

OPERATING ON GRADES

The biggest task when climbing a grade generally will be maintaining a reasonable rate of speed. When possible, pre-plan the climb and probable shift requirements according to traffic conditions and grade to be climbed. When approaching a hill, gradually move the throttle all the way down if necessary to maintain governed RPM and remain at full throttle as the vehicle starts up the grade. If there is sufficient power to maintain satisfactory road speed without engine laboring, remain in that gear for the entire grade. Whenever a grade proves too great for the gear that you are in and the engine begins to labor, ease off on throttle as necessary and allow speed to drop off to the next lower shift point before downshifting to the next gear. Speed usually drops off quickly while shifting so shift should be made rapidly. Additional downshifting should be performed in the same way, as necessary. By riding each gear down to the next shift point, you will get over your grades in the best possible time with minimum shifts.

On downhill operation, the engine provides most efficient braking when run at or near top RPM in the operating range BUT REMEMBER the governor has no control over the engine speed when it is being pushed by a heavy vehicle. When the engine exceeds the rated governed RPM while descending a grade or downshifting at the high end of the operating range, engine overspeed can result in serious damage. On downhill operation, use the vehicle brakes and gears in combination to keep vehicle speed under control and engine below rated governed RPM.

TRANSMISSION SYSTEM

Your Grove carrier is equipped with a Roadranger RTO 613 transmission which provides 13 speeds forward and 3 speeds in reverse. As the carrier is normally used as a highly mobile crane that might be used for both ON and OFF highway application, no hard and fast rules can be given for all gear shifting sequences.

A "rule of thumb" definition of highway "shift points" or "shift speeds", are those speeds attained at governed engine speed in each ratio. It is important that these speeds be learned in order to avoid clashing gears while shifting and to take advantage of the proper ratios for existing road and terrain conditions.

**ROADRANGER RT0613
TRANSMISSION OPERATION**

NOTE: CLUTCH OPERATION IS PERFORMED IN THE SAME SEQUENCE AND MANNER AS PREVIOUSLY DESCRIBED FOR UPSHIFTING AND DOWNSHIFTING STANDARD TRANSMISSIONS. SHIFT RANGES ARE SELECTED BY THE THREE POSITION RANGE SELECTOR AIR VALVE KNOB MOUNTED ON THE TRANSMISSION GEAR SHIFT LEVER. THE BUTTON CONTROLLED COUNTERSHAFT BRAKE IS USED ONLY TO ASSIST INITIAL GEAR ENGAGEMENT WHEN VEHICLE IS STANDING STILL.

The RT0613 model transmission has 13 progressive forward speeds and 3 reverse. It consists of a 5 speed front section and a 3 range auxiliary section. Ratios in the front section are used once through LOW range, once through INTERMEDIATE range and once through DIRECT range of the auxiliary; however, only 3 ratios in the front section are used when the auxiliary is in the LOW range. This gives a 3-5-5 repeat shift pattern.

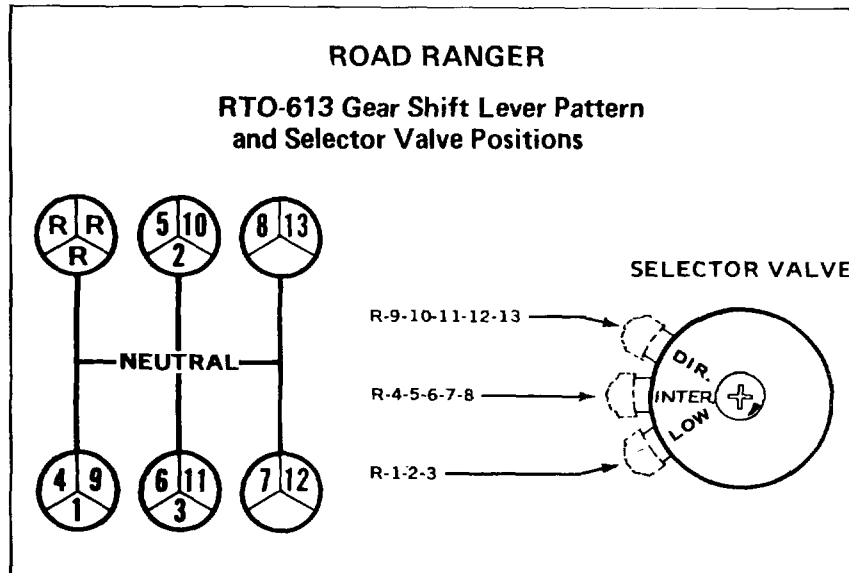

DETAILED SHIFTING INSTRUCTIONS.

In the following instructions, it is assumed that the driver is familiar with motor trucks and tractors, and that he can coordinate the necessary movements of the shift lever and clutch pedal to make progressive and selective gear engagements in either direction, up or down.

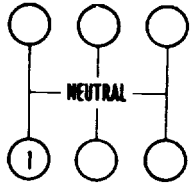
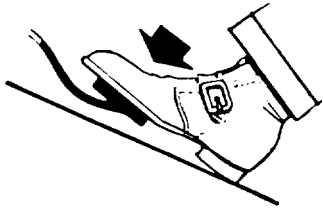
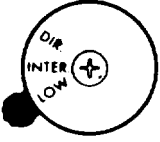

UPSHIFTING

1. With the transmission in neutral, start engine and bring vehicle's air pressure to normal.
2. Make sure the selector valve is in the LOW range position.

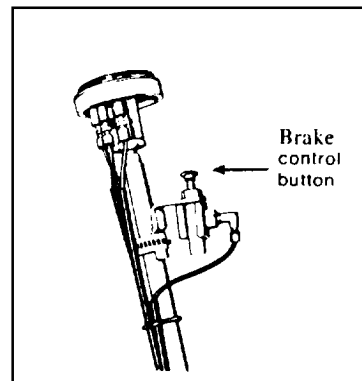

3. Disengage clutch, press down control button and shift into first.

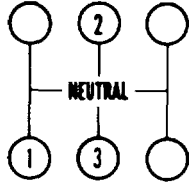

4. Shift from 1st speed through 2nd and to the 3rd speed gear position.

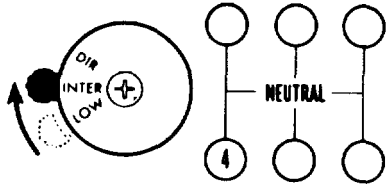

5. Move the selector from LOW to INTERMEDIATE range, and immediately shift to the 4th speed gear position. After the selector valve is moved, the auxiliary will shift as soon as there is a relief in torque

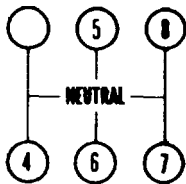

6. Shift progressively from 4th through 5th, 6th, and 7th to the 8th speed gear position.

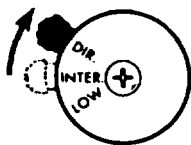

7. Move the selector from INTERMEDIATE to DIRECT range.

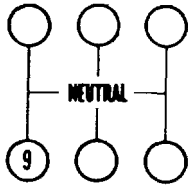

8. Move the gear shift lever to the 9th speed gear position. The auxiliary section will automatically shift from INTERMEDIATE to DIRECT when the gear shift lever reaches neutral.

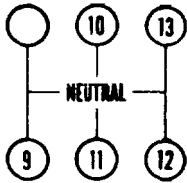

9. Shift upward from 9th through 10th, 11th and 12th to the 13th speed gear position.

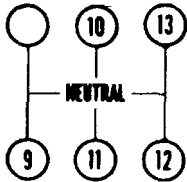

DOWNSHIFTING

1. Move the shift lever from the 13th speed position through each successive lower speed to the 9th speed gear position.

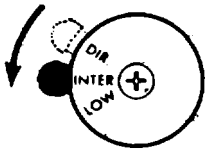

2. When in 9th gear and ready for the next down shift, move the selector valve from DIRECT to INTERMEDIATE Range.

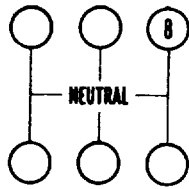

3. Move the shift lever to the 8th speed gear position. As the lever reaches neutral the auxiliary will automatically shift from DIRECT to INTERMEDIATE range.

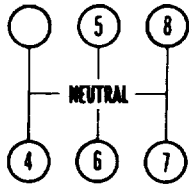

4. Shift from the 8th speed gear position through each gear and to 4th.

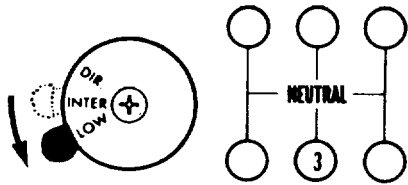

5. Move the selector valve from INTERMEDIATE to LOW and immediately shift to the 3rd speed gear position. The auxiliary section will shift as soon as there is a relief in torque.

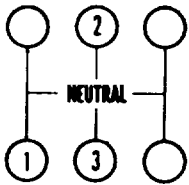

6. Downshift from 3rd to 2nd and to 1st.

SKIP SHIFTING.

Skip shifting may be accomplished when upshifting through any range, providing the higher range position is selected prior to the gear shift. This also applies to downshifting. DO NOT SELECT RATIOS WHERE ENGINE OVERSPEEDS OR ENGINE LABORING MIGHT OCCUR.

REVERSE GEARS.

DO NOT ATTEMPT TO MAKE ANY RANGE SHIFTS EITHER UP OR DOWN WHEN THE VEHICLE IS MOVING IN REVERSE. STAY IN THE RANGE ORIGINALLY SELECTED. COUNTERSHAFT BRAKE MUST BE USED PRIOR TO SHIFTING INTO REVERSE GEAR.

REDUCING SPEED.

When slowing down for a "stop" or "slow" sign, shift down through the individual short steps. By following this procedure the compression of the engine will slow the vehicle. The life of brakes can thus be prolonged.

AIR BRAKE SYSTEM

SERVICE BRAKES.

Air operated service brakes are provided on 8 wheels with pressure supplied by an engine mounted 12 CFM compressor. Normal operating air pressure is between 95 and 125 psi. If tank pressure drops below 70 psi, the low pressure warning buzzer will operate indicating approach of an unsafe braking condition and automatic application of the spring brakes.

PARKING AND AUTOMATIC SPRING BRAKES.

Both rear axles are equipped with automatic spring brakes which are held in the released position by air pressure. These also serve as parking brakes. Normal operation for parking is accomplished by pulling up on the parking brake knob and pushing down to release. Do NOT use for stopping vehicle except in case of emergency as a severe sudden stop will result. An auxiliary air supply tank is provided for brake release if towing operation might be required. Mechanical release is also possible. Refer to Component Manufacturer's Manual for details.

BRAKE OPERATION SERVICE BRAKES.

For most effective braking and for maximum life from brake system components, the following suggestions are made:

Air brakes have light pedal operation and the driver is cautioned to use extreme care in application until a good "feel" is achieved.

Use the engine as a brake when approaching a stop or when going down a long grade. On a downgrade, use the same transmission gear as would be needed to go up the same grade. **DO NOT ALLOW ENGINE TO EXCEED GOVERNED SPEED.**

When necessary to use brakes to reduce vehicle speed on a

downgrade, use on-and-off application to minimize heat and wear. Do not hold a continuous brake application or slide the wheels.

When driving on slippery pavement or under icy conditions, alternately and smoothly apply and release brakes to prevent skidding.

Keep tires properly inflated. Improperly inflated tires can reduce the efficiency of brakes.

After driving through water, dry the brakes by applying lightly while maintaining a slow forward speed with an assured clear distance ahead until brake performance returns to normal.

Regularly check on air pressure gage indication. Gage should never be allowed to fall below 70 psi as automatic spring brakes will actuate. Normal operating pressure range is between 95 and 125 psi.

WARNING : IF LOW PRESSURE OCCURS AND THE BUZZER SOUNDS DURING OPERATION, STOP IMMEDIATELY AND DETERMINE CAUSE OF AIR LOSS. DOWNSHIFT USING ENGINE AS A BRAKE AND MAKE FINAL STOP USING A SINGLE BRAKE PEDAL MOVEMENT TO AVOID EXCESSIVE LOSS OF AIR AND CONSEQUENT SUDDEN ENGAGEMENT OF THE AUTOMATIC SPRING BRAKES.

Make sure air tanks have not accumulated moisture. Moisture in the system and tanks can cause system damage. Frozen systems can become inoperative.

If pressure gage drops over 2 psi per minute with engine stopped, have air system checked for leaks.

PARKING BRAKES.

Parking brakes are controlled by a readily identified "pushpull" knob on dash panel. To apply parking brake, pull knob out -to release, push knob in.

IMPORTANT: MAKE SURE BRAKES ARE RELEASED BEFORE ANY ATTEMPT TO DRIVE OR DRIVE TRAIN DAMAGE WILL RESULT. PARKING BRAKE IS TO BE USED FOR PARKING ONLY. DO NOT USE FOR STOPPING VEHICLE EXCEPT IN CASE OF EMERGENCY AS AN UNPLEASANT, SEVERE, SUDDEN STOP WILL OCCUR.

INTER-AXLE DIFFERENTIAL LOCK

Inter-axle differentials serve the same purpose between front and rear axles of tandem drive units as they do in single axle drives except that it permits one axle, instead of one wheel to rotate faster or slower than the other. This is necessary because when turning corners or operating on uneven terrain, the wheels on the two axles in the tandem assembly are going at different speeds. This would also occur if tires were mismatched by wear or size, between the front and rear tandems.

By LOCK OUT of the inter-axle differential, both axles are forced to turn at the same speed regardless of slippage on one axle, thus delivering power to the axle that does have traction.

OPERATING INSTRUCTIONS

IMPORTANT: SHIFT TO LOCK POSITION ONLY WHEN AXLES ARE MOVING AT SAME APPROXIMATE SPEED OR WHEN AXLES ARE COMPLETELY STOPPED. FAILURE TO DO THIS WILL CAUSE TREMENDOUS INSTANTANEOUS STRAIN ON THE GEARS AND SHIFTING COLLAR RESULTING IN SERIOUS DAMAGE. WHEN SHIFTING TO UNLOCK, RELEASE THROTTLE SUFFICIENTLY TO REDUCE TORQUE TO THE DRIVE TRAIN TO A MINIMUM.

Simple rules to remember in operation of the use of the Inter-Axle Differential Lock are:

1. Use UNLOCK with good traction and favorable operating conditions.
2. Use LOCK with poor traction and unfavorable operating conditions.

ENGINE POWER TAKE-OFF

ENGINE FRONT-MOUNTED PTO

Power take-off units that are driven from the front of the engine by a drive shaft, have a disconnect feature which is controlled from the carrier cab by a push-pull control. Engine start and warm-up should be completed prior to PTO engagement. -

IMPORTANT: THIS UNIT IS ENGAGED OR DISENGAGED BY A DOG TOOTH SLIDING COLLAR WHICH MOVES ON SPLINES. IT IS IMPERATIVE THAT THIS ENGAGEMENT BE MADE WITH THE ENGINE STOPPED TO AVOID DAMAGE TO THE DOG TEETH. IF ENGAGEMENT IS NOT MADE EASILY AND COMPLETELY, ENGAGE ENGINE STARTER MOMENTARILY WITHOUT ALLOWING ENGINE TO START.

After PTO is engaged, start engine in the normal manner and operate at fast idle to warm-up the hydraulic oil before accelerating to governed RPM.

Disengagement should be made with the engine stopped. Avoid road travel with the PTO engaged. Check PTO engagement signal light before any operation.

BEFORE OPERATION

Now that you have become acquainted with your carrier, establish a schedule of daily pre-operation checks that will assure you of maximum reliability and performance. Make notes of discrepancies or malfunctions in order to assist your maintenance crew in keeping your equipment in top condition.

Items listed for check are not considered complete or always applicable to a particular operation and should be varied as experience dictates.

SUGGESTED DAILY SCHEDULE

RADIATOR. Add coolant to correct level. In winter check specific gravity of anti-freeze.

FUEL. Check tank for quantity. Check fuel gage for proper indication.

ENGINE. Check crankcase oil level.

AIR CLEANER. Remove rubber dust collector and clean.

LEAKAGE. Check for oil, fuel, coolant and air leaks.

TIRES. Check pressure when tires are cold.

AIR RESERVOIR. Open drain cocks periodically to remove moisture and sediment.

AIR GAGE. 75 psi minimum before moving. 95 to 125 psi maximum operating pressure.

OIL PRESSURE. Check for 10 to 20 psi idle, 40 to 60 psi @ governed speed.

VOLTMETER. With switch on and engine off, indicates condition of battery. With engine running, indicates condition of generating system.

LIGHTS. Replace any defective lamps/fuses, etc.

HORN. Check operation.

COOLANT TEMPERATURE. Gage should indicate 170° to 185° F. If temperature exceeds 200°, stop vehicle and correct cause of excessive temperature.

WINDSHIELD WIPER, Check operation and condition of blade.

WINDSHIELD WASHER. Check operation and reservoir level.

PARKING BRAKE. Check for proper operation and adjustment.

CLUTCH PEDAL. Check for free pedal travel.

EXHAUST RAIN CAP. Check for free operation.

GOOD DRIVING HABITS

STARTING ENGINE. With clutch disengaged, note starter action for condition of battery and starter. Limit cranking period to 30 seconds or less. Allow starter to cool before next attempt.

Don't Race A Cold Engine!

ENGINE TEMPERATURE. Before entering high speed traffic conditions, allow engine to reach operating temperature. Normal cruising temperature is between 170°F and 185°F. Don't remove radiator pressure cap or add coolant when engine is overheated. Idle engine while adding coolant slowly.

Don't Drive An Overheated Engine!

CLUTCH. To avoid damage, engage without "shock loading" to drive train, especially on grades under heavy loads.

Don't Ride the Clutch Pedal!

SHIFTING. Avoid gear clashing by synchronizing engine and carrier speeds. Don't permit load to drive engine above governed speed. Operate in a gear low enough to allow engine to accelerate to or to maintain governed RPM when applying full throttle. Allowing engine to labor causes excessive strain on engine which could damage pistons, rings, cylinder walls or bearings.

Use Same Gear Downhill As Uphill!

PERFORMANCE AND ECONOMY. Performance, fuel economy and air pollution control is best in normal operating range from 3/4 to governed engine speed.

Save Fuel - Select Correct Gear!

OBSERVE INSTRUMENTS. Glance at instruments frequently. When trouble is indicated, take prompt corrective action.

BRAKING. Avoid sudden stops because constantly making such stops may cause failure of braking and driving parts. When stopping on slippery pavement, alternately and smoothly apply and release brakes to prevent skidding. When slowing for a stop, leave clutch engaged as long as possible to utilize the braking effect of the engine. When forward speed has dropped to a little above idling speed, push clutch pedal in, and brake to a stop. Shift to neutral, release clutch pedal and set parking brake.

Save Your Brakes - They May Save You!

STOPPING ENGINE. After a hard run, allow engine to idle a few minutes before shutdown to stabilize the temperature of all engine parts.

PARKING. Use parking brake for parking only. Check frequently to be certain brake is adjusted to lock and hold vehicle when parked. Do not use for braking vehicle when in motion except in emergency. When parking on a grade, use chocks under rear wheels. Do not leave diesel engine vehicles in gear; if vehicle should move, the engine will start by heat of compression.

GENERAL INSPECTION. Make it a habit at stops, to walk around your carrier to look for fuel, oil and coolant leaks and condition of tires, wheel nuts, springs, lights, etc.

Stop Trouble Before It Stops You!

TABLE OF CONTENTS

**SECTION II.
FUEL
and
LUBRICANTS**

SUBJECT	PAGE NO.
DIESEL ENGINE FUEL OIL	31
DIESEL ENGINE LUBRICATING OIL	33
Oil Quality	33
Mil-L-2104C Lubricants	33
Mil-L-46167 Lubricant	34
Multigrade Oils	34
Cold Weather Operation	34
Oil Changes	34
Oil Filtration	35
LUBRICANT RECOMMENDATIONS	36
Drive Gear Lubricants	36
Wheel Bearing Grease	36
Chassis Grease	36
Power Steering Fluid	37
Transmission Lubricants	37
Clutch Release Bearing Lubricant	37
LUBRICATION CHART	38
CAPACITY CHART	39
CHASSIS LUBRICATION	40

**DIESEL ENGINE
FUEL OIL SPECIFICATIONS**

The quality of the fuel oil used for high-speed diesel engine operation is a major factor in satisfactory engine performance and life. The fuel oils selected must be clean, completely distilled, stable and non-corrosive. Enlist the aid of your supplier in obtaining proper fuel oil. The responsibility for clean fuel lies with the fuel supplier as well as with the operator.

DISTILLATION RANGE, CETANE NUMBER, and SULFUR CONTENT are three of the most important properties in the selection of diesel fuels for optimum combustion and minimum wear. Engine speed, load, and atmospheric temperature influence the selection of the fuels with respect to distillation range and cetane number. THE SULFUR CONTENT OF THE FUEL MUST BE AS LOW AS POSSIBLE, to avoid excessive deposit formation and premature wear.

Diesel fuels are generally marketed according to ASTM DESIGNATION D975 and only distillate fuels No. 1-D and 2-D are considered satisfactory for diesel engines. These fuels should not be confused with the domestic type furnace oils ASTM D396 which have similar properties but are not always satisfactory for engine use due to their varying composition, cetane number, and distillation range.

As a guide to the selection of the proper fuel oil for various applications refer to the Fuel Oil Selection Chart and the ASTM Classification.

FUEL OIL SELECTION CHART

Type Engine Service	General Fuel Classification	Final Boiling Point (Max.)	Cetane Number (Min.)	Sulfur Content (Max.)
Light load and speed with considerable Idling	No. 1-D	5500F	45	0.30%
	Winter No. 1-D	6000F	40	0.50%
Light load and speed	Summer No.1-D	6000F	45	0.50%
	Winter No. 1-D	600°F	45	0.50%
Medium load and speed	Summer No. 2-D	6750F	45	0.50%
Heavy load and high speed with Idling	Winter No. 2-D	6750F	45	0.50%
	Summer No. 2-D	6750F	40	0.50%
Heavy load and high speed	No. 2-D	6750F	45	0.50%

NOTE: FOR MOST SATISFACTORY ENGINE LIFE, USE ONLY THOSE NO. 2D DIESEL FUEL OILS CONTAINING 0.50% OR LESS SULFUR. WHERE MINIMUM EXHAUST SMOKE IS REQUIRED OR WHERE LONG PERIODS OF IDLING OR COLD WEATHER CONDITIONS BELOW 32°F ARE ENCOUNTERED, THE MORE VOLATILE OR LIGHT DISTILLATE FUELS ARE RECOMMENDED.

ASTM CLASSIFICATION OF DIESEL FUEL OILS

	No. 1-0	-No. 2-D
Flash Pt.; °F Min.	100	125
Carbon Residue; %	0.15	0.35
Water and Sediment; (% by Volume) Max.	Trace	0.10
Ash; % by Wt.; Max.	0.01	0.02
Distillation, °F 90% Pt.; Max.	550	640
Min.		540
Viscosity at 100°F;centistokes Min.	1.4	2.0
Max.	2.5	4.3
Sulfur; % Max.	0.5	0.7
Cetane No.; Min.	40	40

Engine operation at altitudes above 5,000 feet requires use of next lighter class of fuel oil than would normally be used.

During cold weather engine operation, the "cloud point" (the temperature at which wax crystals begin to form in the fuel oil) should be 10°F below the lowest expected fuel temperature to prevent clogging of the fuel filters by wax crystals.

**DIESEL ENGINE
LUBRICATING OIL SPECIFICATIONS
OIL QUALITY.**

There are hundreds of commercial crankcase oils marketed today. Lubricants marketed for heavy duty diesel service consist of refined crude oil to which has been added additives compounded to meet the desired engine performance levels. Oil additive selection is based on evaluations conducted by the oil supplier; therefore, satisfactory OIL QUALITY is the responsibility of the oil supplier. (The term oil supplier is applicable to refiners, blenders and rebranders of petroleum products, and does not include distributors of such products.) Experience has shown that oil performance in commercial heavy duty diesel service applications varies from brand to brand.

Obviously engine manufacturers or users cannot completely evaluate the hundreds of commercial oils; therefore the selection of a suitable lubricant in consultation with a reliable oil supplier, strict observance of his oil change recommendations (used oil sample analysis can be of value), and proper filter maintenance will provide your best assurance of satisfactory oil performance.

Diesel engine lubricant recommendations are based on general experience with current lubricants of various types and give consideration to the commercial lubricants presently available.

RECOMMENDATION. ⁽¹⁾

MIL-L-2104C LUBRICANTS.

Diesel engines have given optimum performance and experienced the longest service life with the MIL-L-2104C, SAE 30 oils. MIL-L-2104C oils have superseded the older MIL-L-2104B and Supplement 1 oils. MIL-L-2104C, SAE 30 oils should be used during run-in prior to initial oil drain and are recommended for continued use thereafter. Contact a reliable oil supplier and obtain his assurance that his product has been tested and given good performance in diesel engines. An SAE 30 oil of MIL-L-2104C performance level is recommended for year-round use. The use of

(1) Military and engine manufacturers lubricant specifications are subject to change and equipment users should keep informed of the latest recommendations.

lower viscosity oils or Multigrade products will usually result in less than nominal engine life.

MIL-L-46167 ARCTIC LUBE OILS FOR OPERATION BELOW TEMPERATURES OF -20°F.

For temperatures below -20°F, lubricating oil, Arctic, MI L-L-46167 is required for the TMS300-5.

MULTIGRADE LUBRICATING OILS.

Multigrade oils are NOT recommended. An SAE 30 grade is desirable for year-round use when cold starting can be accomplished. Multigrade oils should be considered only as the "last resort" to facilitate starting when prolonged exposure to temperatures below freezing is unavoidable and adequate starting aids are unavailable.

Experience clearly indicates that Multigrade oils are NOT comparable to SAE 30 lubricants for heavy duty diesel service. Cylinder liner scuffing, liner port and ring groove deposit levels are all greater using Multigrade lubricants. This results in shortened engine life.

COLD WEATHER OPERATION.

Cold weather starting can be aided when immersion type electrical coolant heaters can be used. Other practical considerations, such as the use of batteries, cables and connectors of adequate size, generators or alternators of ample capacity, proper setting of voltage regulators, ether starting aids, oil and coolant heater systems, and proper fuel selection will accomplish starting with the use of SAE 30 oil. For complete cold weather starting information, consult an authorized diesel service outlet.

OIL CHANGES.

It is recommended that new engines be started with 100 hour oil change periods. For highway vehicles this corresponds to approximately 1,000 to 2,000 miles. The drain interval may then be gradually increased, or decreased with experience on a specific lubricant. Also consider the recommendations of the oil supplier (analysis of the drained oil can be helpful here) until the most practical oil change period for the particular service has been established.

Solvents should not be used as flushing oils in running engines. Dilution of the fresh refill oil supply can occur which may be detrimental.

OIL FILTRATION.

Heavy sludge deposits found on the oil filter elements at the time of an oil change must be taken as an indication that the detergency of the oil has been exhausted. When this occurs, the oil drain interval should be shortened. Since abrasive dust, metal particles and carbon material accumulate in the lubricating oil during engine operation, the oil filter elements must be replaced each time the oil is changed.

NOTE: THE MANUFACTURER'S WARRANTY APPLICABLE TO DIESEL ENGINES PROVIDES IN PART THAT THE PROVISIONS OF SUCH WARRANTY SHALL NOT APPLY TO ANY ENGINE UNIT WHICH HAS BEEN SUBJECTED TO MISUSE, NEGLIGENCE OR ACCIDENT. ACCORDINGLY, MALFUNCTIONS ATTRIBUTABLE TO NEGLIGENCE OR FAILURE TO FOLLOW THE MANUFACTURER'S LUBRICATING RECOMMENDATIONS MAY NOT BE WITHIN THE COVERAGE OF THE WARRANTY.

LUBRICANT RECOMMENDATIONS

Specific recommendation of brand and grades of lubricants cannot be made because of regional availability, operation conditions and the continual development of improved quality in the lubricant laboratories. For specific types of lubricants such as required for drive units, wheel bearings, etc., it is suggested that this manual and component manufacturer's maintenance manuals be reviewed with a reliable supplier who must assume the responsibility for recommendations.

Lubricants that meet military specifications for a specific usage will serve as the best guide to final selection.

DRIVE GEAR LUBRICANTS.

"Standard" SAE 90 viscosity lubricants are to be used in units that operate under average conditions except where extreme low temperatures prevail when "optional" SAE 80 viscosity lubricants may be required. This multipurpose extreme pressure gear oil must contain SCL type additives and provide necessary and suitable load-carrying characteristics to prevent scoring and wear, have good stability in storage and service and give good resistance to corrosion. Fillers or any other substances which produce an artificial viscosity are not permitted. An API-GL-4 or API-GL-5 lubricant best meet these requirements.

WHEEL BEARING GREASE.

This grease shall be a homogenous combination of refined petroleum oil and stable soaps or thickeners which will produce a smooth textured product in an NLGI Grade No. 2 consistency. It shall not contain corrosive or abrasive materials and it shall inhibit corrosion in the presence of moisture.

CHASSIS GREASE.

This NLGI Grade No. 0 grease shall be a homogenous combination of refined mineral oil and metallic soap or a mixture of metallic soaps. The grease shall not contain any fillers which adversely affect

the lubricating qualities of the product. It may have additives that give a high degree of protection against corrosion of metal parts and oxidation of grease. This product shall be a non-corrosive, and may be water-resistant but not waterproof, smooth fiber grease of excellent mechanical and storage stability.

POWER STEERING FLUID.

MIL-L-2104C oils, viscosity SAE 01W is normally recommended. Automatic transmission fluid may be used in this system but DO NOT USE hydraulic brake fluid, shock absorber fluid or similar oils.

TRANSMISSION LUBRICANTS.

Straight mineral gear oil Grade SAE 90 (or SAE 80 in extreme cold temperatures) is preferable. Lubricants purchased under these specifications shall be well refined mineral oils, free from water, sediment, acid or any other substance detrimental to proper performance. It does not have extreme pressure characteristics. Refer to component manufacturer's service manual for alternative lube. MIL-L-2104C Heavy Duty Engine Oils Grade SAE 50 for above 10° F or SAE 30, below +10° F, may be used.

CLUTCH RELEASE BEARING LUBRICANT.

High temperature special lubricants that are available from most reputable suppliers should be used. Typical lubricants are Mobil Grease No. 5, Marfac No. 3, Arm-Vac No. 781 or equivalent.

LUBRICATION CHART

The lubrication chart in this section reflects a typical chassis. Lube point locations are general, as changes in manufacturer and vendor component design may result in relocation and/or number of lube fittings, fill plugs, drain plugs, etc.

Specific "brand name" lubricants are not referenced since most all nationally known oil suppliers' products are suitable for use, providing they meet the requirements of the MIL Specs and standards appearing in the FUEL AND LUBRICANT RECOMMENDATIONS section of this handbook.

Should any conflict of information arise between lubricant recommendations for vendor components and those recommended in the applicable vendor's publication, contact the nearest vendor representative, as changes in their recommendations may occur after issuance of this publication.

LUBRICANT CAPACITIES

	U. S. Qts	Liters
ENGINES.		
6-71N.....	21*	19.9
TRANSMISSION.		
Roadranger (RTO-613)	8	7.6
REAR AXLES.		
Front Tandem (Non-Planetary)	37 pts	17.5
Rear Tandem (Non-Planetary)	36 pts	17.0
Differential case (each)	30 pts	14.2
STEERING GEAR.		
Gear Box	4	3.8
Hydraulic Fluid.....	8	7.6

COOLANT CAPACITIES

	U. S. Qts	Liters
ENGINES.		
6-71N.....	54	51.1

*Add 2 U.S. Quarts (1.9 Liters) for Filter.

ITEM NO	LUBE POINTS	LUBRICANT I SYMBOL	FREQUENCY LUBRICATION
1	Engine Crankcase	EO	1,000 miles
2	Engine Oil Filter	Replace	1,000 miles
3	Crankcase Breather	Check and Clean	1,000 miles
4	Alternator	EO	1,000 miles
5	Water Pump	WPG	1,000 miles
6	Deleted		
7	Accelerator Linkage	EO	1,000 miles
8	Air Cleaner	Clean or Replace	1,000 miles
9	Clutch Pedal Shaft	CG	1,000 miles
10	Clutch Release Bearing	CG	1,000 miles
11	Gear Shift Control	CG	1,000 miles
12	Clutch Cross Shaft	CG	1,000 miles
13	Transmission	GO	1,000 miles
14	Drive Shaft Support Bearings	CG	1,000 miles
15	Speedometer Cable	EO	10,000 miles
16	Tachometer Cable	EO	10,000 miles
17	Equalizer Beam Center Pins	CG	1,000 miles
18	Equalizer Boom End Pins	CG	1,000 miles
19	Drive Shaft Universals	CG	1,000 miles
20	Drive Shaft Slip-Joints	CG	1,000 miles
21	Steering Gear Housing	GL	1,000 miles
22	Tie-Rod Ball Joints	CG	1,000 miles
23	Steering Knuckles	CG	1,000 miles
24	Front Wheel Bearings	WBG	10,000 miles
25	Drag-Link U-Joint	CG	1,000 miles
26	Drag-Link Ends	CG	1,000 miles
27	Rear Axle Differential	GO	1,000 miles

***LUBRICANT CODE**

- | | |
|-----------------------------------|-------------------------------|
| EO - Engine Oil | EPG - Extreme Pressure Grease |
| GO - Gear Oil SAE 90, Summer | WBG - Wheel Bearing Grease |
| SAE - 80, Winter | MPG - Multi-purpose Grease |
| BG - Ball & Roller Bearing Grease | |
| CG - Chassis Grease | |

*Reference should be made to the Lubricant Recommendation Section of this manual. Specific oil and grease as recommended by component manufacturers are always highly desirable, however, Multi-purpose grease usually has qualities that meet requirements of a variety of single-purpose greases. Consult your supplier for recommendations.

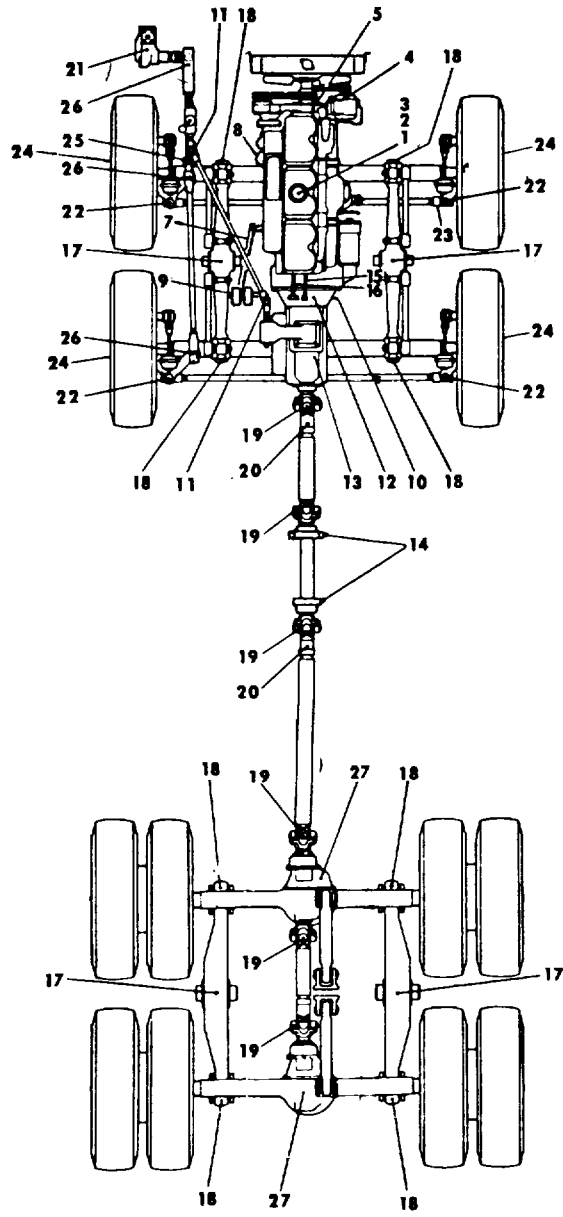

TABLE OF CONTENTS

**SECTION III.
SERVICING
and
PREVENTIVE MAINTENANCE**

SUBJECT	PAGE NO.
SERVICING AND PREVENTIVE MAINTENANCE CHART.....	43
SERVICING AND PREVENTIVE MAINTENANCE	44
Engine Oil and Filter	44
Coolant	44
Hoses	45
Radiator	45
Fuel.....	45
Fuel Strainer.....	45
Air Cleaner.....	45
Air Box.....	46
Blower.....	46
Starting Motor.....	46
Alternator	46
Battery	47
Tachometer Drive.....	47
Throttle Control.....	47
Belts.....	47
Fan	47
Engine tune-up	48
Clutch	48
Transmissions	49
Drive Axles	49
Universal Joints.....	49
Front Axles and Steering Gear.....	49
Wheel Bearings.....	50
Brake System	50
Wheels and Tires	50
TIRE LOADING AND PRESSURE CHART	51

**SERVICING AND
PREVENTIVE MAINTENANCE**

*ITEM	Hours	Daily	50	100	200	300	500	1000	2000
1. Engine oil and Filter		X		X					
2. Coolant		X							
3. Hoses							X		
4. Radiator		X						X	
5. Fuel		X							
6. Fuel strainer		X							
7. Air cleaner		X							
8. Air box								X	
9. Blower								X	
10. Starting motor						X			
11. Alternator				X					
12. Battery			X						
13. Tachometer drive				X					
14. Throttle control					X				
15. Belts					X				
16. Fan								X	
17. Engine tune-up									
18. Clutch and Master Cylinder			X						
19. Transmissions			X					X	
20. Drive Axles			X					X	
21. Universal Joints			X						
22. Front axles & steering gear			X						
23. Wheel bearings								X	
24. Brake system		X	X						
25. Wheels & tires		X	X						

SERVICING AND PREVENTIVE MAINTENANCE CHART

This suggested chart is not to be construed as a fixed schedule or a complete listing because of variations in equipment, maintenance scheduling and operating conditions. It will be noted that neither this chart or the Lubrication Chart lists minor items that are common to all vehicles, such as control linkages, door hinges, etc. Judgment and analysis of what is required for proper servicing has no substitute.

Each schedule should include previous schedules, adjusted as service experience indicates requirements.

*Items are listed in the same sequence on the following pages with brief details of each operation.

SERVICING AND PREVENTIVE MAINTENANCE

1. Check engine crankcase oil level daily before starting engine. When level reaches low mark, fill as near to high mark as possible using same grade and brand of oil as originally used. (Do not overfill.)

It is recommended that new engines be started with 100-hour oil change periods. For highway usage this corresponds to approximately 3,000 miles or for short-haul operation, approximately 1,000 to 2,000 miles. The drain interval may then be gradually increased, or decreased following the recommendations of an independent oil analysis laboratory, or oil supplier (based upon the sample analysis) until the most practical oil change period for the particular service has been established.

At oil change period, run engine until water reaches operating temperature. Shut down engine and drain crankcase before engine cools. Drain oil filter and install new filter elements and gaskets. It is recommended that cartridge be presoaked by filling filter body with new engine oil prior to replacing cover. After filling with new oil run engine for about five minutes and check for leaks. Stop engine and recheck oil level; add system makeup oil if necessary.

2. Check coolant level daily and maintain the level near the top of radiator upper tank.

Clean the cooling system every 1,000-hours, using a good cleaning compound in accordance with instructions on the container. Following the cleaning operation, rinse and reverse flush the cooling system thoroughly with fresh water; then fill the system with soft water, adding a good grade of rust inhibitor. This interval may be lengthened until, normally, this cleaning is done only in the spring or fall. The length of this interval will, however, depend upon an inspection for rust or other deposits on the internal walls of the cooling system. Do NOT wait for the first frost before filling the system with anti-freeze.

3. Inspect all of the cooling system hoses at least once every 500-hours for signs of deterioration. Replace the hoses as necessary.
4. Inspect the exterior of the radiator core every 1,000-hours and if necessary, clean it with a quality grease solvent such as Oleum and compressed air. It may be necessary to clean the radiator more frequently if the engine is being operated in dusty or dirty environment. Automatic radiator shutters should be checked daily for obstruction and operation.
5. Keep the fuel tank filled to reduce condensation to a minimum. This is especially important during periods of wide temperature changes, high humidity or periods of non-usage. Select the proper grade of fuel in accordance with the fuel oil specifications. Open the drain at the bottom of the fuel tank every 500-hours to drain off any accumulated water or sediment.
6. Drain approximately one-fourth pint of fuel from the strainer daily to remove sediment and water by opening the cock at the bottom of each shell. Install new elements every 300-hours or when plugging is indicated.

A method of determining when elements are plugged to the extent that they should be changed is based on the fuel pressure at the cylinder head fuel manifold and the inlet restriction at the fuel pump. In a clean system, the maximum pump inlet restriction must not exceed six inches of mercury. At normal operating speeds (1600 to 2100 RPM), the fuel pressure should be between 50-70 psi. Change the fuel filter elements whenever the inlet restriction (suction) at the fuel pump reaches twelve inches of mercury at normal operating speeds and whenever the fuel pressure at the manifold falls to 45 psi.

7. Air cleaners vary widely in the requirement for cleaning. Daily cleaning of rubber dust collector cup and visual inspection for debris is a must. Under adverse conditions it may be necessary

to remove and clean the air cleaner dust collector end and filter element every eight hours of operation and under clean conditions weekly or monthly cleaning may be adequate.

Remove dust collector end by removing clamp and clean thoroughly. Remove wingnut and carefully remove element. Tap element lightly to remove loose dirt. Blow out element from the clean side with compressed air. Be careful not to rupture the element. Wash element with non-sudsing household detergent and warm water. Dry with compressed air. Clean upper body thoroughly with a damp cloth and reassemble.

IMPORTANT: MAKE CERTAIN THERE ARE NO AIR LEAKS IN THE SYSTEM OR AIR CLEANER.

Do NOT fail to keep the air cleaner free of contamination as abrasive action and air restriction can cause severe and rapid deterioration of the engine.

8. With the engine running, check for flow of air from the air box drain tubes every 1,000-hours. If the tubes are clogged, remove, clean and reinstall the tubes. Air box drain tubes should be cleaned periodically even though a clogged condition is not apparent. If the engine is equipped with an air box drain tank, drain the sediment periodically.
9. Inspect the blower screen and gasket assembly every 1,000-hours and if necessary clean the screen in fuel oil and dry it with compressed air. Install the screen and gasket assembly toward the blower.
10. Some starting motors do not require lubrication except during overhaul. However, motors which are provided with lubrication fittings (grease cups, hinge capoilers, or oil tubes sealed with pipe plugs) should be lubricated every 300-hours.
11. Inspect alternator terminals for corrosion, loose connections and frayed insulation. Slip rings and brushes can be inspected through the alternator end frame assembly. If slip rings are

dirty, they should be cleaned with 400 grain or finer polishing cloth with alternator in operation. Blow away all dust after cleaning operation. If brushes are worn down close, the holder and/or bearings are rough or loose, the alternator must be rebuilt.

12. Check the specific gravity of the electrolyte in each cell of the battery every 50-hours. If battery does not maintain 1275 specific gravity at 80°F (for each 100 above 80°, add four to required reading and for each 10° below 80°, subtract four) check charging system. If charging system is working properly, battery should be replaced. In warm weather, more frequent checks and addition of water may be required.
13. Lubricate the tachometer drive every 100-hours with an all-purpose grease.
14. Lubricate throttle control and all other linkages with multi-purpose grease or engine oil as required every 200-hours.
15. New drive belts will stretch after the first few hours of operation. Therefore, retighten new fan and alternator belts after one hour and again after eight hours of operation. Thereafter check the tension of the drive belts every 300-hours and adjust if necessary. Too tight a belt is destructive to the bearings of the driven part; a loose belt will slip and wear rapidly.

Replace all belts in a set when one is worn. With multiple belts, make certain that they are matched.

Adjust belt tension so that a firm push with thumb at a point midway between two pulleys will depress the belt 1/2-inch to 3/4-inch. If a belt tension gage is available adjust belt(s) in accordance with schedule and chart in engine manufacturer's operator's manual.

16. Lubricate fan shaft bearings with all purpose grease every 1,000-hours on units equipped with grease fittings. On those units equipped with pipe plugs, remove one plug and loosen

the other to vent trapped air while lubricating.

17. There is no scheduled interval for performing an engine tune up. As long as the engine performance is satisfactory, no tune-up) should be needed. Major adjustments in the valve and injector operating mechanisms, governor, etc., should only be required periodically to compensate for normal wear on parts. For detailed information, refer to the engine operator's manual.
18. Lubricate clutch release bearing after each 50-hours of operation using special lubricant as listed in lubricant recommendation. Engine should be running during lubrication. Do not overlubricate. Check for pedal clearance at this time and lubricate linkage. Check master cylinder fluid level.

If inspection indicates clutch pedal "free travel" is less than 1/2-inch, immediate adjustment of the linkage should be made to restore the approximate 1 1/2-inch measurement. This adjustment is made on the clutch cross-shaft lever itself and not on the slave cylinder adjusting rod. Desired dimensions are shown on the following illustrations.

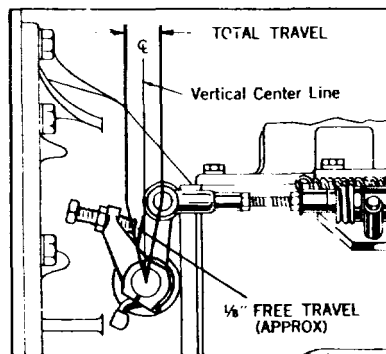

Typical Hydraulic Release Linkage.

NOTE : AFTER THE 1/8-INCH "FREE TRAVEL" ADJUSTMENT IS MADE, RECHECK CLUTCH PEDAL "FREE TRAVEL" WHICH SHOULD CLOSE THE 1/8INCH GAP.

If this adjustment does not result in approximate measurements as shown, refer to manufacturer's service manual for internal clutch adjustment or rework as required.

19. Check transmission oil level at 1,000-mile intervals. Gear oil is to be kept even with the filler opening at all times. Gear oil should be changed after the first 3,000 miles and thereafter at 10,000-mile intervals. Refer to transmission manual for detailed information and recommendations.
20. Drive axle lubricants should initially be changed before a maximum of 3,000 miles and thereafter at 10,000 mile intervals.

Particular attention must be made to magnetic drain plugs.

IMPORTANT: MAGNETIC DRAIN PLUGS LOSE THEIR CAPACITY TO TRAP METAL PARTICLES IF NOT REPLACED FREQUENTLY BY A CLEAN UNIT.

NOTE : REFERENCE TO AXLE LUBRICATION MANUAL IS IMPORTANT FOR PROPER SERVICE.

21. Universal joints should be inspected for wear at 1,000 mile intervals and lubricated with multi-purpose grease.
22. Front axle knuckle pins, steering cross tube and end assembly and drag link ball sockets should be lubricated every 1,000 miles with chassis lubricant. Power steering reservoir oil level should be checked at this time.

Frequent inspection for bolt tightness and, rubber deterioration should be made on a safety check basis. Rubber bushings must be replaced in accordance with manufacturer's service bulletin. Special tools will be required.

23. Wheel bearings should be cleaned and repacked every 10,000 miles or twice a year (spring and fall). Bearings should be repacked even with the inside diameter of bearing cups with wheel bearing lubricant.
24. Air brakes should be checked for proper operation before each trip. Make certain air tanks are drained of water daily if not equipped with an automatic moisture ejector device. At each 50 hour period, check warning buzzer and automatic spring brakes for operation by releasing air pressure below 70 pounds.
If pressure gage drops over 2 psi per minute with engine stopped, check system for leaks and correct before further operation. Air compressor filter should be cleaned after 250 hours of operation, oiled lightly with clean engine crankcase oil and reinstalled. Lubricate brake actuating system at all points periodically using a No. 1 NLGI grade of high temperature waterproof grease. Refer to manufacturer's maintenance manual for detailed information.
25. Wheel lug nuts should be checked for proper torque. Tires should be visually inspected for condition and checked for recommended cold inflation pressure. Refer to Trouble Shooting Section for tire wear indication of improper wheel alignment and to the Service and Maintenance Manual for adjustment procedures.

IMPORTANT: ALL OF THE TANDEM FRONT END AXLE ALIGNMENT ADJUSTMENTS MUST MATCH OR ERRATIC STEERING AND RAPID TIRE WEAR WILL RESULT.

Toe-in measurements should be 1/16 in. to 1/8 in., camber 1° positive and caster 2° positive. When rear tire changes are indicated on the through drive type tandems, it will be necessary to replace them with matched tires throughout (within 3/4 in. of the same rolling circumference at the same tire pressure). Mount the two largest tires on one side of one axle and mount the two smallest on the opposite side of the same axle. Mount the four other tires on the other axle in the same manner.

TIRE LOADING AND PRESSURE CHART

NOTE

RECOMMENDED TIRE PRESSURES VARY WITH WEIGHT DISTRIBUTION. CHECK YOUR TIRE INFLATION DECAL.

TIRE SIZE	TIRE LOAD LIMITS AT VARIOUS COLD INFLATION PRESSURES													
	35	40	45	50	55	60	65	70	75	80	85	90	95	100
10 00 20 Ply Rating	5260	5690	6090	6480	6860	7210	7560	7890	8270	8530	8840 (12)	9140	9430 (14)	
11 00 20 Ply Rating	5740	6200	6650	7070	7480	7870	8250	8610	8970	9310 (12)	9650	9980 (14)		
12 00 20 Ply Rating	6540	7070	7570	8060	8520	8960	9400	9810	10210	10610	10990 (14)	11370	11730	12080 (16)
*12 00 24 Ply Rating	7240 (6)	7830	8390	8920 (8)										
*13 00 24 Ply Rating	8510 (6)	9200	9860 (8)	10490	11100	11670	12240	12780 (12)	13300	13810	14310	14800 (16)		
14 00 20 Ply Rating	8980	9710	10400	11070	11710	12310	12910	13480	14030	14570	15100	15610	16110 (18)	16600 (20)
*14 00 24 Ply Rating	10070	10830 (8)	11610	12350	13060	13740	14400 (12)							
14 00 24 Ply Rating	10020	10830	11610	12350	13060	13740	14400	15040	15650	16250	16840	17420	17970	18520 (20)
*16 00 24 Ply Rating	13670	14780	15840	16850 (12)										
16 00 25 Ply Rating	13120	14180	15200	16170	17100	17990	18860	19690	20500	21280	22050	22810	23530 (24)	
18 00 25 Ply Rating	16940	18320 (12)	19630	20880	22090 (16)	23230	24360	25440 (20)	26470	27490 (24)				
21 00 25 Ply Rating	21810	23580	25270	26890 (16)	28430	29900 (20)	31350	32740 (24)	34070	35380	36660 (28)			
24 00 25 Ply Rating	28170	30450	32640 (18)	34720	36720	38620	40490 (24)	42280	44010	45700 (30)				
24 00 29 Ply Rating	30170	32670	34960 (18)	37180	39330	41370	43370 (24)	45290	47140	48950 (30)				
36 00 41 Ply Rating	76650	82880	88820	94470	99930	105110	110190	115070	119770	124370	128870 (48)			
36 00 51 Ply Rating	84970	91820	98400	104670	110720	116450	122080	127490	132690 (42)	137790	142780 (30)	147660	152330	157000 (36)

TABLE OF CONTENTS

**SECTION IV.
TROUBLESHOOTING GUIDE**

SUBJECT.....	PAGE NO.
FOREWORD	53
TROUBLESHOOTING DIESEL ENGINES.....	54
CLUTCH	58
TRANSMISSION.....	58
PROPELLER SHAFT.....	59
AIR BRAKES.....	59
FRONT AXLE AND STEERING	61
TIRES	61

TROUBLE SHOOTING GUIDE

FOREWORD

Trouble shooting is an organized study of the problem and development of a logical sequence of procedures for investigation and correction of the problem.

Operators handling the same carrier every day soon develop a danger signal sense when abnormal operation occurs. Alert attention to these danger signals prevents major failures, insures dependable operation and increases the life of the units. Operators should depend on their well-developed senses of feeling, hearing, seeing and smelling and replace their sense of taste in this type of work with a generous amount of "common sense".

A specific section of this Trouble Shooting Guide is devoted to items peculiar to diesel engines with a general Trouble Shooting section following. Only basic and common items are included in this latter section. Reference should be made to component manufacturers service manuals or specialized service personnel should be consulted in the more complex areas.

When trouble occurs, start checking the easy-to-get-at items first. After these areas have been checked out, proceed to the more complicated items. Chances are, that if you follow this procedure, you will find the cause in a minimum amount of time, thus saving costly down time.

TROUBLE SHOOTING DIESEL ENGINES

TROUBLE AND SYMPTOMS	PROBABLE CAUSES Check causes given on next page In sequence shown -
ENGINE CRANKS, WILL NOT START	
Fuel Pressure Normal.....	la,b,d,24,11,10b, 16,17,18,19,5,8
Fuel Pressure Low	lb,c,2,3,4,24
Fuel Pressure High.....	la,10b,14,24
ENGINE STARTS, ERRATIC FIRING ALL CYLINDERS	
Low Fuel Pressure	la,c,2,3,4
Adequate Fuel Pressure	
Erratic at Idle Speed Only.....	6b
Erratic at Both Idle and High Speeds	
Smoke.....	lb,20b,5,24,3d,9,26,21
No Smoke1c,2,3,11,18,13,19,410,5,22
ENGINE MISSING ON ONE OR MORE CYLINDERS	
Missing at Idle Speed Only	6b,24,8,9,10,5
Missing at Idle and High Speed	
Smoke	5,9,24,26,22,21,27,6a
No Smoke.....	a,c,2,3,4,9,10,5,21,22,6a
Blow-by at Crankcase Breather	23,27
ENGINE STALLS FREQUENTLY	
Low or No Fuel Pressure	c,2,3,4,17
Fuel Pressure Adequate	
No Smoke.....	6b,11,13,17,16d,5,10
Black Smoke	11,20,5,21,9
ENGINE SURGES.....	6b,3a,d,8,17, la,c,d,18,12,19,15,5,10,16d
ENGINE WILL NOT REACH NO LOAD GOV. RPM . . .	1,6a,11,13,12,16,3,2,5,10,26
ENGINE OVERSPEEDS.....	6a,14,11,10b,15,12,20a
ENGINE LACKS POWER	
No Smoke.....	1,3,22,10,5,6a,11,19,13,17
Black or Brown Smoke	1,9,5,13,24,21,22,23,27,29
Blue or White Smoke.....	22,23,27,20,29
ENGINE WILL NOT SHUT DOWN	a,3,19,15,12c,10a,b
ENGINE OVERHEATS	22,29,5.9c,21,23,20
FUEL CONSUMPTION EXCESSIVE.....	3c,9,22,24,21,5,10,6a,27,20b,c,d,13
LUBRICATING OIL CONSUMPTION EXCESSIVE	25,22,20a,24,21c,23,27,26
EXCESSIVE FUEL PRESSURE	7,4
EXCESSIVE OIL PRESSURE	30,31
NO OR LOW OIL PRESSURE	30,31,28
LOW COMPRESSION.....	23,27,26,22,21
CRANKCASE BUILDUP.....	26,22,23,27

PROBABLE CAUSES

FUEL SVSTEM

- 1a. Emergency Shutoff Cock closed, or partly closed.
 - b. Air Intake Manifold Valve closed, or partly closed.
 - c. Fuel Tank Vent plugged, partly plugged.
 - d. Low Ambient Air Temperature, use starting aid.
2. Fuel Supply Pump inoperative or leaking.
- 3a. Air leaks or restriction, suction side of Fuel System.
 - b. Fuel Filters clogged.
 - c. Filter Air Bleed too large or missing.
 - d. Filter Air Bleed plugged, valve closed.
4. Injection Pump Overflow Valve leaky, stuck open or closed.
- 5a. Injection Pump Internal adjustment incorrect.
 - b. Worn Injection Pump Shaft Bearings.
 - c. Loose Injection Pump Drive Assembly, timing incorrect.
- 6a. Improper Setting of Governor or High Speed Stop.
 - b. Improper Setting of Governor Idle Speed.
7. Fuel Return Line Plugged or crimped.
8. Delivery Valve stuck or leaking.
- 9a. Faulty Nozzle Spray, leaky, opening pressure incorrect.
 - b. Nozzle Cap nut improperly torque.
 - c. Nozzle(s) Valve stuck.
 - d. Bent or broken spindle or spring.
 - e. Nozzle improperly installed in cylinder head (binding).
- 10a. Injection Pump Plunger stuck.
 - b. Injection Pump Rack stuck.
 - c. Injection Pump Plunger(s) worn.
- 11a. Governor Throttle Shaft Linkage binding, or sticky Governor parts.
 - b. Improper Setting of Governor Throttle Linkage.
 - c. Governor Drive Assembly binding.
 - d. Broken or weak Speeder Springs.
 - e. Solenoid stuck.

MECHANICAL GOVERNOR EQUIPPED 1

- 2a. Worn Governor Sliding Sleeve Assy.
 - b. Worn Governor Flyweight Fingers.
 - c. Worn Governor Linkage, excessive end-play.
13. Improper rack, gap cam angle or cam plate setting.
14. Broken Governor Throttle Spring or Linkage disengagement.
15. Displaced Governor Throttle Shaft Bushings, Yoke binding.

HYDRAULIC GOVERNOR EQUIPPED

- 16a. Press, Relief Valve Spring broken.
 - b. Press, Relief Valve stuck open.
 - c. Shutdown Valve stuck or open.
 - d. Restricted Oil Supply.
17. Air In Governor Oil Feed, insufficient oil pressure.
18. Loose Governor Ball-Head Drive Assembly, excess Ball-Head Tang clearance.
19. Incorrect Speed Droop Setting, or length of speed follower spring.

TURBOCHARGER EQUIPPED

- 20a. Turbocharger passing oil.
 - b. Restricted Air Intake, clogged Air Cleaner.
 - c. Nozzle Ring restricted, slow charger rpm.
 - d. Binding Turbocharger Impeller.

ENGINE PROPER

- 21a. I m proper Valve clearance, Camshaft or Lifters worn.
 - b. Broken or weak Valve Springs.
 - c. Valve Guides worn or gummed.
 - d. Valve(s) stuck or burned, poor seat contact.
- 22a. Leaky Cylinder Head Gasket.
 - b. Leaky Gaskets or Seals.
- 23a. Rings stuck or worn.
 - b. Rings broken or Improperly fitted.
24. Poor Compression. (See Low Comp.) 25. Clogged Crankcase Breather or Pipe.
26. Blow-by.
27. Scuffed pistons or cylinder sleeves.
28. Excessive clearance In main or connecting rod bearings.
29. Water leak in combustion chamber, cracked head.

LUBRICATION SYSTEM

30. Restriction in Oiling System, faulty gage.
31. Pressure Relief Valve stuck closed, or faulty Oil Pump Relief Valve.

**TROUBLE SHOOTING GUIDE
(CONT)**

MECHANICAL KNOCKS

LOOSE, WORN, OR BURNED-OUT MAIN OR CONNECTING ROD BEARINGS.

Slight mechanical knocks which often gave advance warning of bearing troubles in the gasoline engine are not as easily detected in the diesel. This is mainly due to the higher sound level of the diesel, caused by injection system sounds, i.e., plunger pumping action, delivery valve action, and injection nozzle opening. For this reason, the operator must pay closer attention to the instrument panel gages. Reduced lube oil pressure at normal operating speeds accompanied by noticeable increase in sound level may indicate bearing failure long before detected by sound only.

VALVES.

BURNED VALVES AND SEATS. Engine misses, especially at low speeds.

WEAK OR BROKEN VALVE SPRINGS. Erratic missing at low or high speeds when under load.

STICKING VALVES. Loss of power or popping sound at air intake or exhaust.

TAPPET NOISE. Excessive clearances cause noise when cold; this decreases at normal operating temperature.

CAMSHAFT.

Noise due to loose bearings or end-play. Generally occurs at about half maximum engine speed.

TIMING GEAR NOISE.

Loose or worn gears rattle or knock; tight gears hum.

COOLING

Economical operation of the engine requires maintaining operating temperatures of 170° to 185°F. The lack of enough coolant can be most expensive, so maintaining a tight non-leaking cooling system cannot be over-emphasized.

Cooling troubles result in either overheating or overcooling, which are caused by the following.

OVERHEATING.

FAN BELT. Broken or loose.

EXTERNAL LEAK. Radiator, cylinder head gaskets, coolant pump seals, thermostat gasket or core plugs. (Watch for coolant leaks on floor after truck has been stored.)

INTERNAL LEAKS. Cracked block or cylinder head, loose or defective cylinder head gaskets. (Can be noted by raised oil level in crankcase or by foam on dipstick.)

CLOGGED OR LEAKY RADIATOR. Rusty coolants settle in and clog radiators. Corrosion perforation of the thin metal and mechanical failure of soldered joints.

DEFECTIVE COOLANT PUMP. Can be checked by watching the action of the coolant in the radiator or by inserting a sight glass into the upper hose while the engine is idling.

INCORRECT ENGINE TIMING. Check timing if no other causes are found.

POOR DRIVING PRACTICE. Using incorrect transmission speed.

DRAGGING BRAKES. When not completely released-or improperly adjusted.

THERMOSTAT. Check for correct opening temperature.

RADIATOR CAP. Check for correct pressure rating.

OVERCOOLING.

Due to improper thermostat or shutter operation which results in engine sludging and in loss of power or fuel economy.

CLUTCH

The most important item in the drive line is the clutch, as it has a tremendous amount of work to do in transmitting engine power.

Clutches require regular inspection and the recommended adjustment of the clutch assembly release bearing clearance and pedal adjustment must be carefully maintained in order to obtain satisfactory service. Refer to Manufacturer's Service Manual for correct adjustment.

SLIPPING. Experienced on grades with heavy loads and fast acceleration. To check with transmission in high gear, the engine should stall with the brakes applied and the clutch engaged.

GRABBING. Indicated by rough engagement, which will jerk the vehicle; can be caused by improper adjustment, poor driving practice, loose engine mounting bolts, or scored pressure plate.

DRAGGING. Indicated by gear clash during shifting because of incomplete disengagement. Correct by adjusting linkage to obtain additional free pedal travel. May also be caused by warped pressure plate or driven disc.

TRANSMISSION

Typical symptoms of transmission troubles are noise, shifting difficulties, "jumping-out-of-gear" or lubricant leaks. Heavy duty transmissions normally have a limited amount of gear noise; however, many noises attributed to transmissions are caused by other

parts of the drive line such as axle, propeller shaft, universal joint or clutch. These should be checked before removing the transmission to locate the trouble. The basic transmission troubles are indicated as follows:

NOISY TRANSMISSIONS. May be due to worn or damaged parts, improper or insufficient lubricant, misalignment of transmission with clutch housing or torsion vibration transmitted by the clutch.

Refer to Manufacturer's Service Manual for detailed information.

SHIFT DIFFICULTIES. May be due to improper adjustment of the clutch linkage, incorrect driving practice, binding of the shift rails or the gear lubricant being too heavy.

"JUMPING-OUT-OF-GEAR". May be caused by weak or broken shifter rail poppet springs, misalignment of bell housing or transmission parts, bent or loose shifter forks or broken snap rings, or improperly adjusted linkage, permitting gears or shaft to move lengthwise.

PROPELLER SHAFT

Carriers are equipped with one or more propeller shafts, depending upon the wheel base connecting the transmission to the rear axle. Universal joints permit movement of the rear axle in relation to the power plant assembly and the splined end takes care of the changes in length due to spring deflection.

Excessive noise and vibration indicates trouble of the drive line due to the universal joint flanges not being parallel, worn universal joint bearings, loose center bearing, unbalanced propeller shaft or lack of lubricant.

AIR BRAKES

The air brake system consists of three main elements; the compressor with governor and reservoirs supply the air pressure; the brake application valve controls the braking pressures; and the brake

chambers perform the work on the carrier brake mechanism. Air brake troubles, in general, are indicated by:

NO BRAKES. Due to no air pressure, broken lines or connections, bad leak or defective brake valve.

SLOW BRAKE APPLICATION. Caused by slack brakes, low air pressure, faulty lines or lack of lubrication in the brake mechanism.

SLOW BRAKE RELEASE. May be due to broken brake release springs, binding of the brake rigging or defective brake valve.

BRAKES GRAB. Due to grease on lining, out-of-round brake drums or defective brake valve.

UNEVEN BRAKES. Need adjustment or relining; has grease on lining; leaky brake chamber or brake drum is out-of-round.

LOW AIR PRESSURE. Due to bad leak, reservoir drain cock being open, governor not being adjusted properly, defective air gage or worn air compressor.

SAFETY VALVE "BLOWS-OFF". Air pressure in the system is above normal due to the governor being out of adjustment.

EXCESSIVE OIL OR WATER IN SYSTEM. Due to not draining the reservoir often enough, worn compressor rings or dirty air strainer.

PARKING AND SPRING BRAKES

BRAKES NOT HOLDING. Power spring not fully uncage. Spring not fully applying or actuating. Caging bolt damaged or power spring broken. Hold off air not fully releasing.

BRAKES DRAGGING. Low spring hold off pressure (should be -70 psi minimum). Leaking air lines or seals. Plungers tight or sticking. Brake shoe springs not fully returning due to internal binding or breakage.

BRAKES FROZEN OR LOCKED. Lining frozen to brake drum. Release air line frozen due to moisture in the system. Broken air line, fitting or seals. Damaged lining jammed between drum and shoe. Wedge return spring broken jamming unit.

FRONT AXLE AND STEERING

Carriers in heavy duty service require careful attention to front axle and steering maintenance. Special attention should be given to checking all difficulties as the safety of the operator and carrier is directly concerned.

HARD STEERING. May be due to under-inflated tires, front wheel misalignment, excessive friction, lack of lubrication, or loss of power assist.

LOW SPEED SHIMMY. Caused by incorrect caster, front brake drums out-of-round, worn steering knuckle bearings or loose wheel bearings.

HIGH SPEED SHIMMY. Generally due to the tire or wheel assembly not being balanced, unequal tire inflation or worn and maladjusted steering mechanism.

TIRES

Tires should be carefully checked for inflation and condition before each trip. The following wear characteristics indicate the need for alignment work:

INCORRECT TOE-IN. When tire wears from outside to inside of tread with feather edge on inside of rib, and generally is more pronounced in the right tire.

INCORRECT TOE-OUT. When tires wear from inside of tread to outside edge of ribs and is usually more pronounced on the left tire.

INCORRECT CAMBER. Excessive camber causes wear on the outside half of the tire and wear of this type usually takes the form

of deep depressions or waves and no feather edge.

INCORRECT TRACKING. Has feather edge in same manner as toe-in or toe-out characteristics. Check tracking or "dogging" by observation when following the carrier. This is corrected by equalizing the wheel base centers and squaring frame.

INCORRECT CASTER. While caster in itself does not cause tire wear, it may cause an error in camber, toe-in or steering geometry, which results in a wear characteristic of misalignment.

CAUTION : TIRES USED ON MULTIPIECE RIMS SHOULD BE ASSEMBLED AND INFLATED ONLY BY EXPERIENCED, QUALIFIED PERSONNEL. ALWAYS INFLATE TIRES IN A SAFETY CAGE WHENEVER POSSIBLE OR USE A "CLIP-ON" AIR CHUCK AND STAND ASIDE.

TABLE OF CONTENTS

**SECTION V.
APPENDIX**

SUBJECT	PAGE NO.
EXPLANATION OF REQUIRED EMISSION CONTROL MAINTENANCE SERVICES	64
SYMPTOMS OF MALFUNCTIONS WHICH MAY AFFECT ENGINE EMISSIONS	67
REQUIRED OWNER'S EMISSION CONTROL MAINTENANCE SERVICE CHART	68
POWER STEERING SCHEMATIC	69
AIRCRAFT ONLOADING PROCEDURE	70

EXPLANATION OF REQUIRED EMISSION CONTROL MAINTENANCE SERVICES

The following explanation of required emission control maintenance items and service intervals has been keyed by number to corresponding line numbers in the preceding maintenance chart.

More frequent maintenance will be required where an engine is operated under other than normal conditions (e.g., heavy dust, excessive idle.)

- 1 .FUEL FILTERS. Replace elements in the strainer and the filter every 10,000 miles, or when plugging is indicated.
- 2 .INJECTORS. Check injector timing (proper height adjustment between injector follower and body is primary to emission control). The injector timing should be set with the appropriate tool depending on the injector size. Injector timing should be checked, and adjusted if necessary, every 40,000 miles on vehicles used in city,service or every 80,000 miles on vehicles used in other applications.
3. GOVERNOR. Check the engine idle speed and no-load speed every 40,000 miles and adjust as necessary. An idle speed lower than recommended will cause the engine to be accelerated from a speed lower than the speed at which the engine was certified. A no-load speed higher than recommended will result in a full load speed higher than rated, and higher than the speed at which the engine was certified.
4. THROTTLE DELAY. This system limits the amount of fuel that can be injected during acceleration by limiting the rate of injector rack movement with a hydraulic cylinder. The initial location of this cylinder must be set with the proper gage in order to achieve the appropriate time delay. Inspect every 80,000 miles.

5. **DRY TYPE AIR CLEANER.** Under no engine operating condition should the intake restriction exceed 25 inches of water for non-turbocharged engines and 20 inches of water for turbocharged engines. A clogged air cleaner element will cause excessive intake restriction and a reduced air supply to the engine.

Inspect and service the air cleaner element every 20,000 miles, or more often if the engine is operated under severe dust conditions. Check the gaskets for deterioration and replace, if necessary. If the dry type air cleaner is equipped with an aspirator, check for aspirator damage or clogging. Clean and repair as necessary.

6. **OIL BATH TYPE AIR CLEANER.** Clean and refill the air cleaner oil cup every 4,000 to 6,000 miles. Remove and steam clean the air cleaner element and baffles annually. Operation under dusty conditions will require more frequent service.
7. **ENGINE LUBRICATING OIL.** Change the initial lubricating oil at approximately 3,000 miles, and at 4,000 6,000 mile intervals thereafter. Drain intervals may be established on the recommendation of an independent oil analysis laboratory or the oil supplier (based upon the oil sample analysis) until the most practical oil change period has been determined. Check all lubricating oil lines and connections for wear or chafing.
8. **ENGINE LUBRICATING OIL FILTER.** Change the lubricating oil filters when the engine oil is changed.
9. **COOLANT.** Check the coolant level daily before starting the engine. Make sure coolant covers the radiator tubes. Add coolant as necessary. **DO NOT OVERFILL.** Check all cooling system lines and hoses for damage, leaks or loose connections. Tighten or replace as necessary.
10. **TURBOCHARGER.** Inspect mountings, intake and exhaust ducting, and connections for leaks daily. Check oil inlet and outlet lines for tight connections, damaged lines or fittings.

Check for unusual vibrations or noises. If excessive, remove from service and have cause corrected.

11. THERMOSTAT. Check thermostats and seals annually, (preferably at the time the cooling system is prepared for winter operation). Replace the seals if necessary; if seals are functioning properly, the barrel of the thermostat will be lightly polished over the sealing area.
12. BLOWER AND SCREEN. Inspect the blower and screen annually and, if necessary, clean the screen in fuel oil and dry it with compressed air. Install the screen and gasket assembly with the screen side of the assembly toward the blower.
Inspect for evidence of blower seal leakage.

**SYMPTOMS OF MALFUNCTIONS
WHICH MAY AFFECT
ENGINE EMISSIONS**

Certain symptoms of malfunctions are evident to the operator which can indicate the need for service to provide proper emission control. The following information describes some of the common indications of trouble and the usual causes. Operators should be alert to these symptoms and have corrections made promptly.

SYMPTOM	USUAL CAUSES OF PROBLEM
Excessive white smoke.	<p>Indicates unburned fuel in exhaust due to the following:</p> <ol style="list-style-type: none"> 1. Misfiring due to engine not being up to compression. 2. Misfiring due to faulty injector or low compression.
Excessive blue smoke	<p>Indicates lubricating oil in the exhaust due to the following:</p> <ol style="list-style-type: none"> 1. "Pull-over" from the oil bath air cleaner. 2. Leaking blower or turbocharger seals. 3. Improperly sealing oil control rings. 4. Worn valves, valve guides, stems or seals.
Excessive black smoke	<p>Indicates incomplete burning of the fuel due to the following:</p> <ol style="list-style-type: none"> 1. Overfueling due to increased fuel injection from enlarged injector tip orifices. 2. Poor atomization of fuel due to deposits around injector tip. 3. Inadequate air supply due to clogged air cleaners, dirty blower screen, turbocharger failure or increased exhaust back pressure. 4. Overfueling due to engine operation at speeds below 60% of rated speed.

REQUIRED OWNER'S EMISSION CONTROL MAINTENANCE SERVICE CHART

Key No.	MAINTENANCE SERVICES	MAINTENANCE INTERVALS (Months/Miles in Thousands)										SERVICE RECORD		
		6/10	12/20	18/30	24/40	30/50	36/60	42/70	48/80	54/90	60/100	Record Date (Da) & Mileage (Mi) of maintenance operation performance as indicated, and retain invoices of records covering their performance.		
1	Fuel Filters	R	R	R	R	R	R	R	R	R	R			
2	Injectors				I *				I					
3	Governor	Idle Speed				I			I			4,000 -- 6,000 Mi.	Da	
		No Load Speed				I			I			10,000 Mi.	Da	
4	Throttle Delay								I			12 Mo. or 20,000 Mi.	Da	
5	Dry Type Air Cleaner	Element		I		I			I		I	30,000 Mi.	Da	
		Aspirator		I		I			I		I		Mi	
6	Oil Type Air Cleaner	Element		I		I			I		I	24 Mo. or 40,000 Mi.	Da	
		Oil Cup	I	4,000 to 6,000 Mile Intervals										50,000 Mi.
7	Engine Lugging Oil **	R	4,000 to 6,000 Mile Intervals											Mi
8	Engine Lubricating Oil Filter	R	Every Oil Change										36 Mo. or 60,000 Mi.	Da
9	Coolant	I	Daily										70,000 Mi.	Da
10	Turbocharger	I	Daily											Mi
11	Thermostat	I	Annually										48 Mo. or 80,000 Mi.	Da
12	Blower and Screen	I	Annually										90,000 Mi.	Da
	*City service vehicles only **Check level daily & replace initial oil at 3,000 miles.		MAINTENANCE OPERATIONS R = Replace I = Inspect, Correct — Replace if necessary										60 Mo. or 100,000 Mi.	Da

POWER STEERING SCHEMATIC

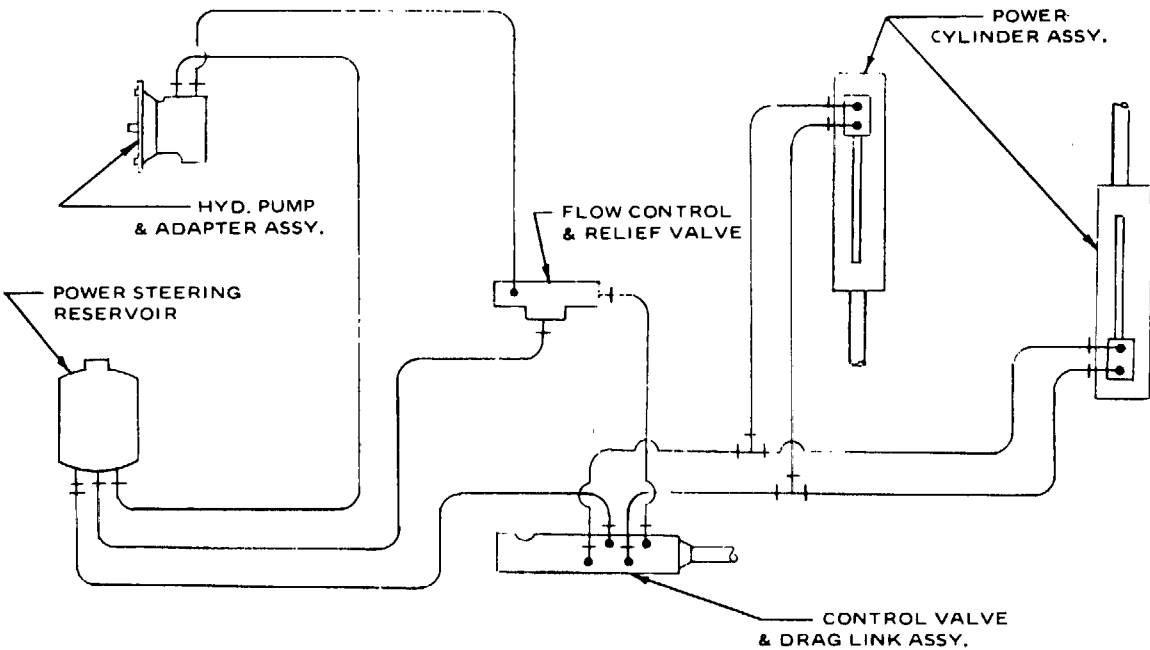

AIRCRAFT ON LOADING PROCEDURE

To facilitate loading and unloading this crane on or off a transport aircraft ramp, provision has been made to block the rearmost rear axle in a down position so the outrigger boxes will clear the ground and the top of the ramp.

The blocks will be found in the sling (tool) box, and instructions for installation appear on a decal on the outside of the superstructure cab in front of the cab door.

NOTE

THE INTER-AXLE DIFFERENTIAL LOCK MUST BE ENGAGED FOR THIS OPERATION TO GIVE THE REAR AXLE TRACTION. AFTER THE CRANE HAS BEEN UNLOADED, DISENGAGE THE INTER-AXLE LOCK AND REVERSE THE BLOCK-UP PROCEDURE TO REMOVE THE BLOCKS.

**SECTION VI.
ADDENDUM**

ENVIRONMENTAL PROTECTION AGENCY PROVISIONS 72

ADDENDUM
1978 EPA NOISE ABATEMENT
PROGRAM
AS
ADMINISTERED BY
GROVE MANUFACTURING COMPANY
(40 CFR PART 205)

BACKGROUND

The Environmental Protection Agency (EPA) was established in the Executive Branch of our Federal government as an independent agency pursuant to Reorganization Plan No. 3 of 1970, effective December 2, 1970, and as amended, in part, the Noise Control Act of 1972.

The EPA was created to permit coordinated and effective governmental action on behalf of the environment. EPA endeavors to abate and control pollution systematically by proper integration of a variety of research, monitoring, standard setting, and enforcement activities. As a compliment to its other activities, EPA coordinates and supports research and antipollution activities by state and local governments, private and public groups, individuals, and educational institutions. EPA also reinforces efforts among other Federal agencies with respect to the impact of their operations on the environment. In all, EPA is designed to serve as the public's advocate for a livable environment.

Grove Manufacturing Company fully recognizes and accepts its part to design, test, and place in commerce the latest "state-of-the art" as regards the protection of the environment and to integrate into its product line sound noise abatement engineering systems consistent with Federal/State mandates and urges owners to maintain the integrity of such systems not specifically due to any law but rather to protect the rights and privileges to a healthier environment for all Americans.

FOREWARD

The information and requirements presented in this addendum will be incorporated in the applicable Carrier Operators Handbook at the earliest convenience of the manufacturer. Until such time, this addendum must be used in conjunction with the applicable Carrier Operators Handbook.

NOISE EMISSIONS WARRANTY

The manufacturer warrants to the first person who purchases this vehicle for purposes other than resale and to each subsequent purchaser that this vehicle was designed, built, and equipped to conform at the time of sale to such first purchaser with all applicable U.S. EPA noise control regulations.

This warranty is not limited to any particular part, component, or system of the vehicle which, at the time of sale to such in any part, component, or system of the vehicle which, at the time of sale to such first purchaser, caused noise emission levels to exceed Federal standards are covered by this warranty for the life of the vehicle.

TAMPERING WITH NOISE CONTROL SYSTEM PROHIBITED

Federal law prohibits the following acts or the causing thereof: (1) The removal or rendering inoperative by any person other than for purposes of maintenance repair, or replacement, of any device or element of design incorporated into any new vehicle for the purpose of noise control prior to its sale or delivery to the ultimate purchaser or while it is in use, or (2) the use of the vehicle after such device or element of design has been removed or rendered inoperative by any person.

LIST OF TAMPERING ACTS

Among those acts presumed to constitute tampering are the acts listed below:

1. Improper Installation Not in accordance with the instruction specified in the Grove Service Manual.
2. Improper Replacement of Components All components listed in the parts listing for this system shall be replaced, when defective, with a certified approved equivalent. However, common hardware such as mounting hardware, clamps, nuts and bolts may be replaced with a functional equivalent.
3. Modification of System The original system must remain intact. No deletions of specified parts nor additions of unspecified parts are permitted.
4. Exhaust Tubing Changes No changes are allowed to the following exhaust tube and fitting parameters:
 - a. Type
 - b. Length
 - c. Size diameter
 - d. Bends, which include: location, amount of bend, bend radius and orientation.
 - e. Tubing location and orientation.
 - f. Lowering height of exhaust gas exit (muffler stack outlet height).

5. Neglect of Replacement of Defective Parts Defective parts may result in improper sealing of the system causing an increase in noise level.
6. Swapping of Parts Exchange of components with so-called, equivalent vehicles, i.e., the same model family but with a different engine configuration.
7. Neglect to Follow Maintenance Recommendations As specified in the Grove Service Manual.

This page intentionally left blank.

PART II



OPERATORS
HANDBOOK

TMS-300-5
SUPERSTRUCTURE

CONTRACT NO. DSA 700 -77-C-8511

FEBRUARY 1978

WARNING

ELECTROCUTION HAZARD TO PREVENT DEATH OR SERIOUS BODILY INJURY

NEVER OPERATE THIS CRANE WITHIN ANY DISTANCE OF A POWER SOURCE OR POWER LINE WITHOUT FIRST NOTIFYING THE POWER OR UTILITY COMPANY.

NEVER OPERATE CRANE, ANY PART THEREOF OR LOAD WITHIN 20 FEET OF ANY ELECTRICAL POWER LINE OR POWER SOURCE OR SUCH DISTANCE AS IS SPECIFIED OR REQUIRED BY LOCAL OR OTHER APPLICABLE SAFETY CODES OR REGULATIONS.

NEVER OPERATE CRANE WITHOUT CONSULTING LOCAL OR OTHER APPLICABLE SAFETY CODES OR REGULATIONS.

NEVER OPERATE, SERVICE, OR MAINTAIN THIS CRANE WITHOUT PROPER INSTRUCTIONS. REMEMBER, IT IS THE EMPLOYER'S RESPONSIBILITY TO IMPLEMENT THE ABOVE AND TO PROVIDE ALL SAFETY DEVICES OR MEANS THAT MAY BE NECESSARY OR REQUIRED FOR ANY USE OPERATION, SET-UP, OR SERVICE.

MAKE SAFETY FIRST---NOT LAST!!! READ YOUR OPERATOR'S HANDBOOK!

NOTE DO NOT REMOVE THIS SIGN OR OPERATOR'S MANUAL FROM THIS CRANE.

STOP !

read this

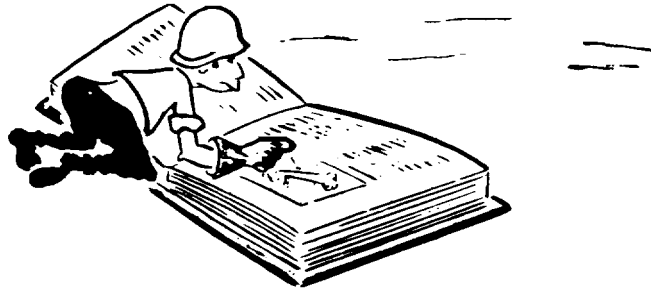

FOREWORD

This handbook is intended to serve as a guide to the owner in properly planning his projects and for the operator to achieve optimum performance of the unit.

While the modern hydraulic crane is exceptionally easy to physically control, its high degree of maneuverability and extreme ranges of operation require that the operator be alert and professionally capable.

To be a professional crane operator who can perform his task in a safe and efficient manner, he must have a thorough operational knowledge of the equipment. He must also have the judgment required for avoidance of all potentially hazardous situations.

TABLE OF CONTENTS

SUBJECT	PAGE NO.
WARNING, CAUTION, AND NOTE DEFINITIONS	2
LOAD CHART	2
Notes to Lifting Capacities.....	2
Notes to Jib Capacities.....	3
RATED LIFTING CAPACITIES	4
RANGE DIAGRAM	8
LINE PULL AND REEVING INFORMATION	10
SAFETY PRECAUTIONS	11
Hand Signals	12
Be Prepared	29
Don't Forget.....	30
CONTROLS, GAGES, AND INDICATORS	32
Controls	32
Gages.....	36
Indicators.....	36
PRE-STARTING INSPECTION.....	38
STARTING PROCEDURE	40
SHUTDOWN PROCEDURE	41
EMERGENCY SHUTDOWN	41
CRANE FUNCTIONS.....	42
Outrigger Operation.....	42
Control Lever Operation	43
Swinging the Boom.....	44
Elevating and Lowering the Boom.....	44
Emergency Procedure.....	45
Telescoping the Boom.....	46
Lowering and Raising the Cable.....	47
PRE-LOAD OPERATION CHECK	48
HANDLING THE LOAD	49
TRAVELING WITH A LOAD	50
ERECTING AND STOWING 32 FT. SWINGAWAY EXTENSION	51
COUNTERWEIGHT REMOVAL	54
COUNTERWEIGHT INSTALLATION	54
INSTALLING CABLE ON HOIST	55
CRANE TRAVELING	57
LUBRICANTS.....	58
LUBRICATION CHART AND SCHEDULE.....	61

This page intentionally left blank.

WARNING, CAUTION, AND NOTE DEFINITIONS

Because safety of the operator and ground personnel and proper use of the equipment are main points of concern, WARNINGS, CAUTIONS, and NOTES are inserted throughout this handbook, as applicable. They are defined as follows:

WARNING

AN OPERATING PROCEDURE, PRACTICE, ETC., WHICH IF NOT CORRECTLY FOLLOWED, COULD RESULT IN PERSONAL INJURY.

CAUTION

AN OPERATING PROCEDURE, PRACTICE, ETC., WHICH, IF NOT STRICTLY OBSERVED, COULD RESULT IN DAMAGE TO OR DESTRUCTION OF EQUIPMENT.

NOTE

AN OPERATING PROCEDURE, PRACTICE, ETC., WHICH IT IS ESSENTIAL TO HIGHLIGHT.

LOAD CHART.

The following information comes directly from the load chart posted in the superstructure cab. This information is of the up most importance to ensure safe and efficient crane operation.

NOTES TO LIFTING CAPACITIES.

1. Do not exceed any rated lifting capacity. Rated lifting capacities are based on freely suspended loads with the machine leveled and standing on a firm supporting surface. Ratings with outriggers are based on outriggers being extended to their maximum position and tires raised free of crane weight before extending the boom or lifting loads.
2. Practical working loads for each particular job shall be established by the user depending on operating condition to include: the supporting surface, wind and other factors affecting stability, hazardous surroundings, experience of personnel, handling of load, etc. No attempt must be made to move a load horizontally on the ground in any direction.
3. Operating radius is the horizontal distance from the axis of rotation before loading to the centerline of the vertical hoist line or tackle with loads applied.
4. "On Rubber" lifting (if permitted) depends on proper tire inflation, capacity and condition. "On Rubber" loads may be transported at a maximum vehicle speed of 2.5 mi/hr (4 Km/hr) on a firm and level surface under conditions specified.
5. Jibs may be used for lifting crane service only. Jib capacities are based on structural strength of jib or main boom and on main boom angle.
6. Operation is not intended or approved for any conditions outside of those shown hereon. Handling of personnel from the boom is not authorized except with equipment furnished and installed by Grove Manufacturing Company.
7. For clamshell or concrete bucket operation, weight of bucket and load must not exceed 80% of rated lifting capacities.
8. Power-telescoping boom sections must be extended equally at all times. Long cantilever booms can create a tipping condition when in extended and lowered position.
9. The maximum load which may be telescoped is limited by hydraulic pressure, boom angle, boom lubrication, etc. It is safe to attempt to telescope any load within the limits of rated lifting capacity chart.

10. With certain boom and hoist tackle combinations, maximum capacities may not be obtainable with standard cable lengths.
11. With certain boom and load combinations, raising of load with boom lift cylinders may not be possible. Operational safety is not affected by this condition.
12. Keep load handling devices a minimum of 12 inches (30 cm) below boom head when lowering or extending boom.
13. If actual boom length and/or radius is between values listed, use lifting capacity for the next longer rated length and/or radius.
14. All load handling devices and boom attachments are considered part of the load and suitable allowances must be made for their combined weights.
15. Operation of this equipment in excess of rating charts or disregard of the instructions is hazardous and voids the warranty and manufacturer's liability.

NOTES TO JIB CAPACITIES.

1. 24 ft. jib and 32 ft. boom extension combination may be used for single line lifting crane service only. Capacities are based on structural strength of 24 ft. jib and 32 ft. boom extension combination at given main boom angle regardless of main boom length.
2. Capacities do not exceed 85% of tipping loads as determined by test in accordance with SAE J-765.
3. Lifting over front of machine with 24 ft. jib is strictly prohibited.
4. **WARNING**
Operation of machine with heavier loads than the capacities listed is strictly prohibited. Machine tipping with jib occurs rapidly and without advance warning.
5. Maximum total length of boom including 32 ft. boom extension for purpose of erecting 24 ft. jib below 10° elevation, over rear or side, is 92 ft.
6. **24 ft. JIB WARNING**
For total boom length including 32 ft. boom extension greater than 92 ft. with 24 ft. jib in working position the boom angle must not be less than 50° since loss of stability will occur causing a tipping condition.

RATED LIFTING CAPACITIES.

There are two graphical presentations of the rated lifting capacities. One provides for lifting on outriggers over the side while the other provides capacities for lifting on outriggers over the rear. The numbers on the vertical axis signify the radius in feet. The horizontal axis shows the boom length in feet. The figure in each block represents the rated lifting capacity in pounds at that particular radius and with that particular boom length. Each block also shows a figure in parentheses. This figure represents the boom angle at that particular radius and boom length.

The following information comes from the load chart in regards to the rated lifting capacity charts.

1. Capacities appearing above bold line are based on structural strength and tipping should not be relied upon as a capacity limitation. Capacities do not exceed 85% of tipping loads as determined by test in accordance with SAE J-765.
2. Capacities for 33 ft. boom length shall be lifted with boom fully retracted, capacities shall not exceed those shown for the 38 ft. boom length.
3. For boom lengths less than 112 ft. with 32 ft. boom extension erected, the rated loads are determined by boom angle only in the column headed by 112 ft. boom.
4. . For boom angle not shown, use rating of next lower boom angle.
5. Boom angle is the included angle between horizontal and the axis of the boom base section after lifting rated load. (See A6-829-002833 for boom angles).

RATED LIFTING CAPACITIES IN POUNDS
33 ft. - 112 ft. BOOM

ON OUTRIGGERS FULLY EXTENDED - OVER SIDE

Radius in Feet	Boom Length in Feet									32 ft. Ext. + 80 ft. **112	
	*33	38	44	50	56	62	68	74	80		
10	50,000 (67.5)	50,000 (71)	50,000 (73.5)	50,000 (75.5)							
12	50,000 (63.5)	50,000 (67.5)	50,000 (71)	50,000 (73)	50,000 (75)	49,000 (76.5)					
15	50,000 (57.5)	50,000 (62.5)	50,000 (66.5)	46,500 (69.5)	43,900 (72)	41,900 (73.5)	40,000 (75.5)	38,600 (77.5)			
20	47,000 (46.5)	43,000 (53.5)	39,500 (59)	36,500 (63)	34,500 (66.5)	32,700 (68.5)	31,400 (71.5)	30,000 (73.5)	28,700 (75)		
25	31,650 (32)	31,650 (43.5)	31,000 (51)	30,000 (56.5)	28,100 (60.5)	26,500 (63.5)	25,300 (67)	24,200 (69.5)	23,100 (71)	17,500 (77.5)	
30		22,390 (30.5)	22,390 (42)	22,390 (49.5)	22,390 (54.5)	22,100 (58.5)	21,000 (62)	20,000 (65)	19,000 (67.5)	14,900 (75)	
35			16,720 (31)	16,720 (41)	16,720 (48)	16,720 (52.5)	16,720 (57.5)	16,720 (60.5)	16,000 (63.5)	13,300 (72)	
40			13,150 (13)	13,150 (31.5)	13,150 (40.5)	13,150 (46.5)	13,150 (52)	13,150 (56)	13,150 (59)	11,700 (69.5)	
45				10,490 (17)	10,490 (31.5)	10,490 (40)	10,490 (46.5)	10,490 (51)	10,490 (54.5)	10,300 (66.5)	
50					8,580 (19.5)	8,580 (32)	8,580 (40)	8,580 (45.5)	8,580 (50)	8,930 (63.5)	
55						7,130 (21)	7,130 (33)	7,130 (39.5)	7,130 (45)	7,800 (61)	
60							5,890 (23.5)	5,890 (33)	5,890 (39.5)	6,840 (57.5)	
65								4,940 (24.5)	4,940 (33)	6,010 (54.5)	
70								4,050 (10.5)	4,050 (25)	5,310 (51.5)	
75									3,180 (13)	4,610 (48)	
80										3,820 (44)	
85										3,140 (40)	
90										2,600 (35.5)	
95										2,160 (30.5)	
100										1,770 (24.5)	
105										1,430 (16.5)	

A6-829-003329 & 002823A

**RATED LIFTING CAPACITIES IN POUNDS
33 ft. - 112 ft. BOOM**

ON OUTRIGGERS FULLY EXTENDED - OVER REAR

Radius in Feet	Boom Length in Feet									32 ft. Ext. + 80 ft.
	*33	38	44	50	56	62	68	74	80	**112
10	50,000 (67.5)	50,000 (71)	50,000 (73.5)	50,000 (75.5)						
12	50,000 (63.5)	50,000 (67.5)	50,000 (71)	50,000 (73)	50,000 (75)	49,000 (76.5)				
15	50,000 (57.5)	50,000 (62.5)	50,000 (66.5)	46,500 (69.5)	43,900 (72)	41,900 (73.5)	40,000 (75.5)	38,600 (77.5)		
20	47,000 (46.5)	43,000 (53.5)	39,500 (59)	36,500 (63)	34,500 (66.5)	32,700 (68.5)	31,400 (71.5)	30,000 (73.5)	28,700 (75)	
25	35,675 (32)	33,300 (43.5)	31,000 (51)	30,000 (56.5)	28,100 (60.5)	26,500 (63.5)	25,300 (67)	24,200 (69.5)	23,100 (71)	17,500 (77.5)
30		25,200 (30.5)	25,200 (42)	25,200 (49.5)	23,500 (54.5)	22,100 (58.5)	21,000 (62)	20,000 (65)	19,000 (67.5)	14,900 (75)
35			21,000 (31)	21,000 (41)	20,000 (48)	18,700 (52.5)	17,700 (57.5)	16,800 (60.5)	16,000 (63.5)	13,300 (72)
40			17,860 (13)	17,860 (31.5)	17,300 (40.5)	16,100 (46.5)	15,200 (52)	14,400 (56)	13,600 (59)	11,700 (69.5)
45				14,680 (17)	14,680 (31.5)	14,000 (40)	13,200 (46.5)	12,400 (51)	11,700 (54.5)	10,300 (66.5)
50					12,110 (19.5)	12,110 (32)	11,500 (40)	10,800 (45.5)	10,100 (50)	8,930 (63.5)
55						10,260 (21)	10,100 (33)	9,460 (39.5)	8,840 (45)	7,800 (61)
60							8,750 (23.5)	8,330 (33)	7,730 (39.5)	6,840 (57.5)
65								7,370 (24.5)	6,790 (33)	6,010 (54.5)
70								6,500 (10.5)	5,980 (25)	5,310 (51.5)
75									5,300 (13)	4,700 (48)
80										4,160 (44)
85										3,700 (40)
90										3,280 (35.5)
95										2,920 (30.5)
100										2,610 (24.5)
105										2,350 (16.5)

A6-829-003328 & -002823A

All load handling devices and boom attachments are considered part of the load and suitable allowances must be made for their combined weights. Listed below are the weight reduction figures for Grove furnished equipment.

32 ft. boom extension (reduction of main boom capacities)

Stowed 350 lbs.

Erected 2350 lbs.

Hook Block 25 Ton, 4 Sheave 585 lbs.

15 Ton, 1 Sheave 310 lbs.

Auxiliary Boom Head 190 lbs.

5 Ton Headache Ball 150 lbs.

7 1/2 Ton Headache Ball 300 lbs.

10 Ton Headache Ball 500 lbs.

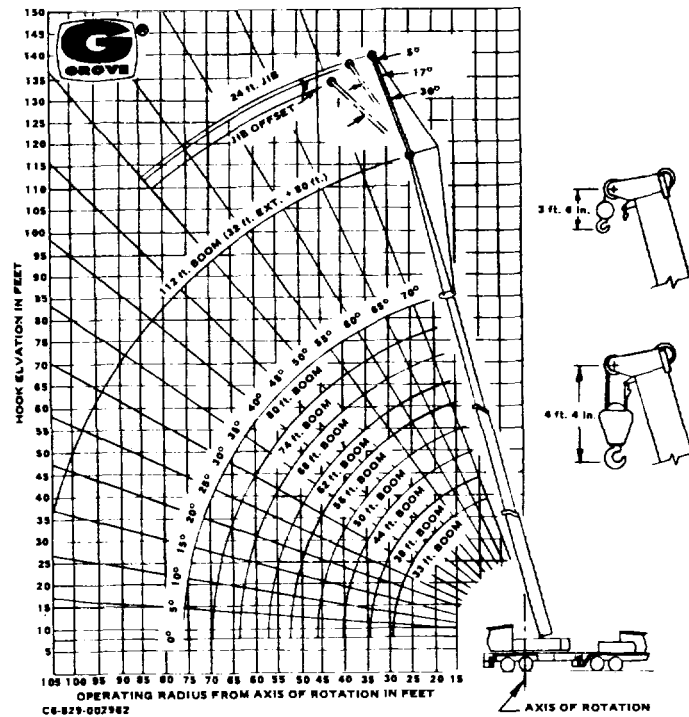

RANGE DIAGRAM.

The range diagram is a graphical presentation of the relationship between hook elevation, operating radius and boom angle. The operating radius is defined as the horizontal distance from a projection of the axis of rotation to the supporting surface before loading to the center of the vertical hoist line or tackle with load applied. The operating radius must be determined manually (i.e. use a tape measure). The boom angle is defined as the included angle between horizontal and the axis of the boom base section after lifting rated load. This angle is shown in degrees on the Krueger control panel. The boom length is the actual length of the boom including the jib, if erected. This measurement must also be made manually (i.e. use a tape measure).

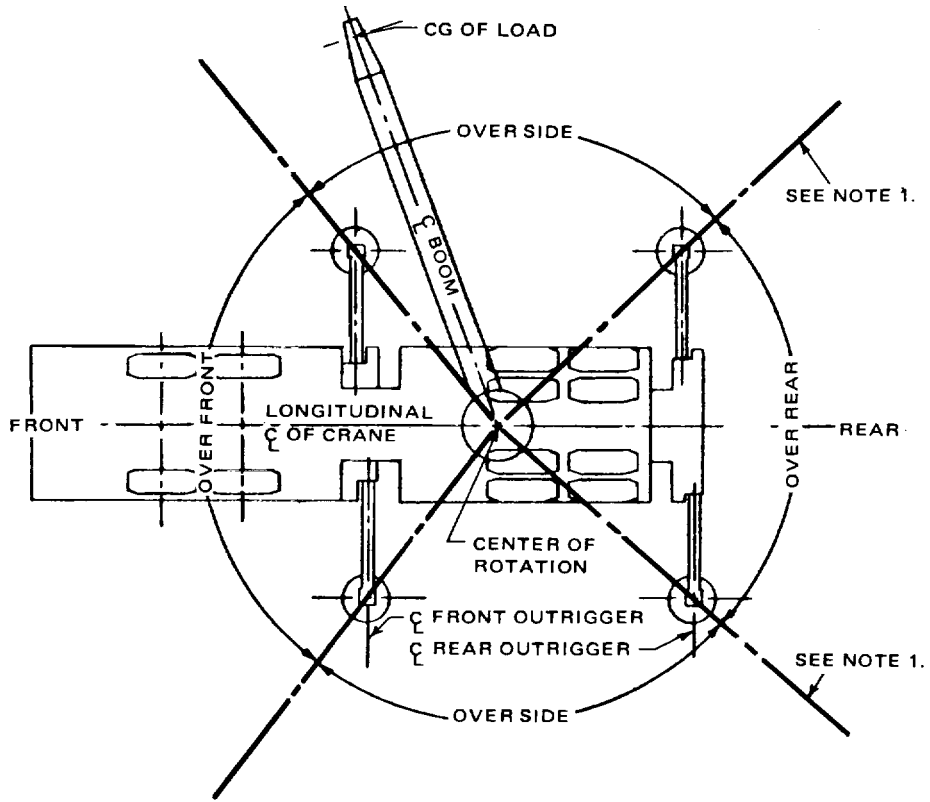

LIFTING AREAS ON OUTRIGGERS

NOTE:

1. BOLD LINES DETERMINE THE LIMITING POSITION OF ANY LOAD FOR OPERATION WITHIN WORKING AREAS INDICATED.

LINE PULL AND REEVING INFORMATION.

The line pull and reeving information appearing in your load chart is most important. The "permissible" line pulls are based on the actual breaking strength of the applicable cable, including a minimum safety margin of 3.5.

WARNING

NEVER EXCEED THE MAXIMUM SINGLE LINE CAPACITY OF ANY CABLE. ADHERE TO THE RECOMMENDED MULTI-PART REEVING (*) INFORMATION.

LINE PULLS & REEVING INFORMATION		
HOISTS	CABLE SPECS	PERMISSIBLE LINE PULLS
MAIN Model 25	*1/2 in.-18 x 19 EIPS	7,714 lbs.
AUXILIARY Model 25	1/2 in.-18 x 19 EIPS	7,714 lbs.

*For multiple part reeving, use one line for each 6,250 lbs. of load or portion thereof.

SAFETY PRECAUTIONS

It is impossible to compile a list of safety items covering all situations.

However, there are basic safety precautions that should be followed during your daily operation. Safety is **YOUR PRIME RESPONSIBILITY**, since any piece of equipment is only as safe **AS THE MAN AT THE CONTROLS**.

With this thought in mind, the following list of safety precautions will help you use the equipment in a safe and efficient manner, along with promoting the safety of others.

REMEMBER, failure to follow just one safety precaution can cause that accident, to men or machine.

Check Capacity Load Chart in Cab. Always CHECK capacity on load chart in cab before making any lifts. Position hoist line to radius required then lift load.

Follow Directions On All Placards. Know what they mean and follow their instructions.



READ IT- AND HEED IT

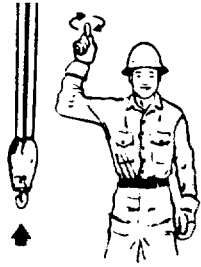

HOIST

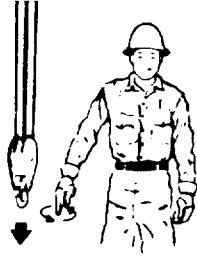

LOWER

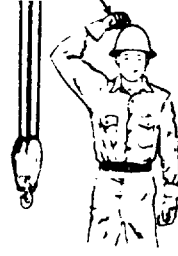

USE MAIN HOIST

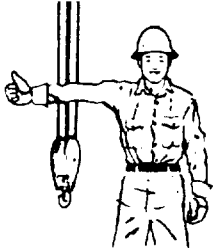

RAISE BOOM



**USE WHIP LINE
(Auxiliary Hoist)**

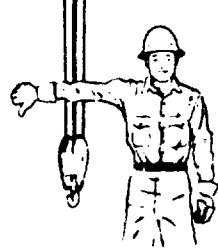

LOWER BOOM

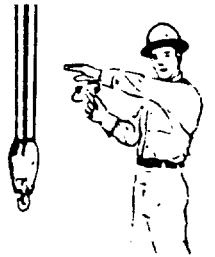

MOVE SLOWLY

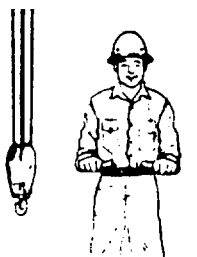

RETRACT BOOM

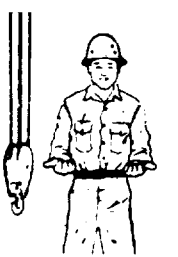

EXTEND BOOM

**HAND
SIGNALS**

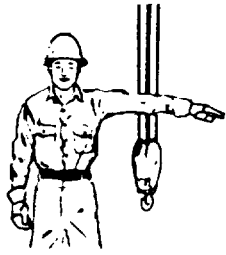

STOP

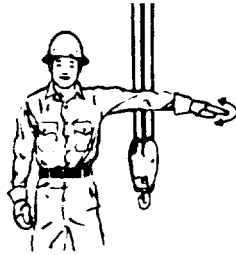

EMERGENCY STOP

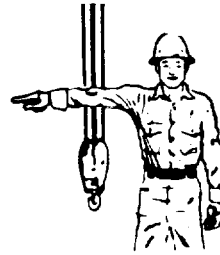

SWING

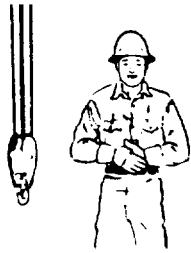

DOG EVERYTHING

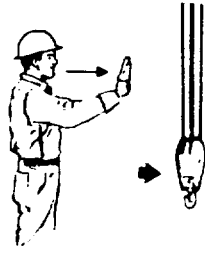

TRAVEL

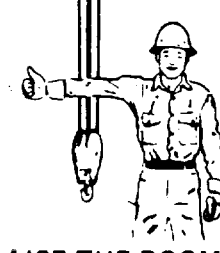

**RAISE THE BOOM AND
LOWER THE LOAD**

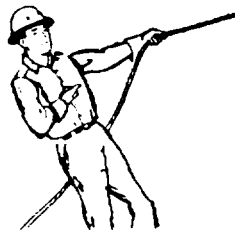

**RETRACT BOOM
(ONE HAND)**

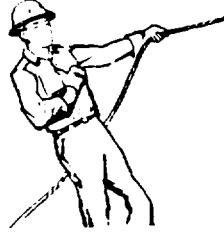

**EXTEND BOOM
(ONE HAND)**

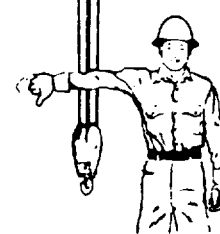

**LOWER THE BOOM AND
RAISE THE LOAD**

**HAND
SIGNALS**

Keep Your Shoes Clean. Before entering control cab, clean any mud or grease from your shoes. This will reduce possibility of your foot slipping off a control pedal, resulting in a possible accident.



DON'T MUDDY THE RUG

Use Outriggers. Unless lifting within "on rubber" capacities, operate with outriggers fully extended so as to remove ALL weight from machine's tires.

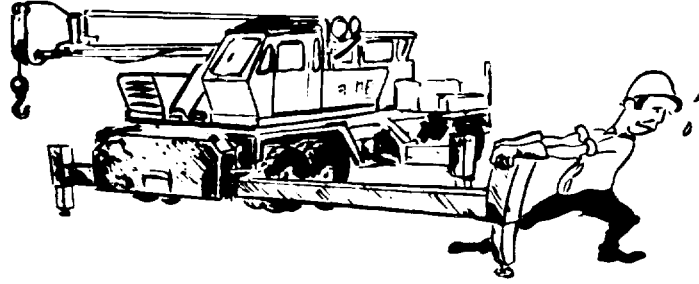

FULLY EXTENDED AND SET WITH SAFETY LOCKS ENGAGED.

Check Machine Stability Before Lifting Loads. Make certain that outriggers (or tires, if lifting on rubber) are firmly positioned on solid surfaces, machine is level, brakes set, and that load is properly rigged and attached to hook. Lift load slightly off ground and recheck stability before proceeding with lift.

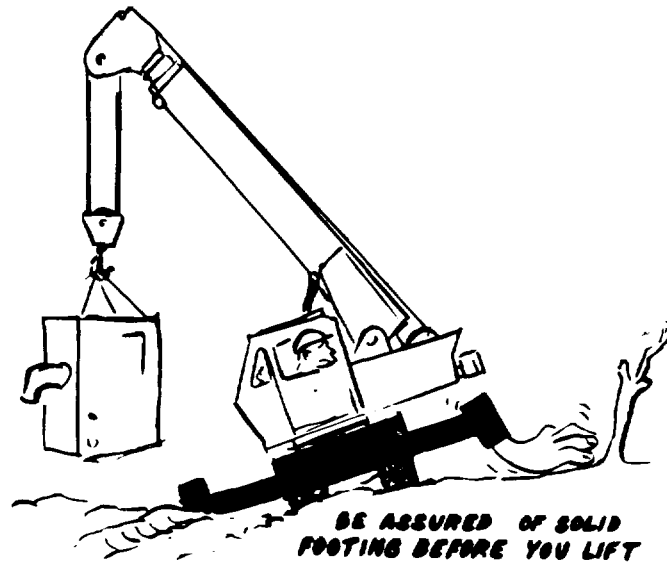

Check Load Limit of Bridges. Before traveling across bridges, check to make certain that they will carry a load greater than machine's weight.

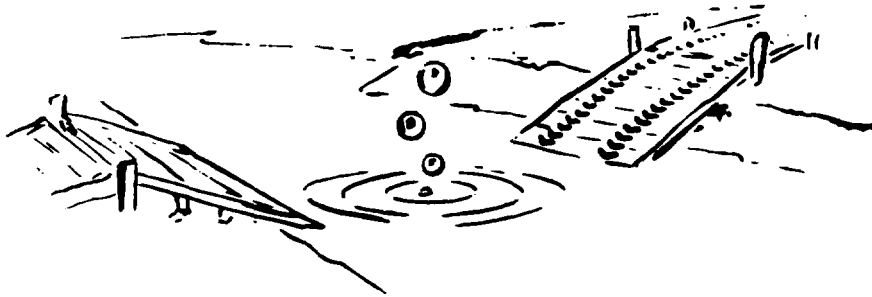

KNOW LOAD LIMITATIONS BEFORE CROSSING

Avoid Electrical Lines and Overhead Cables. If boom should come in contact with electrical lines or overhead cables, stay on machine, until boom is freed or current is cut off. Keep everyone, on the ground, away from machine. If you must get off machine JUMP do not step off.

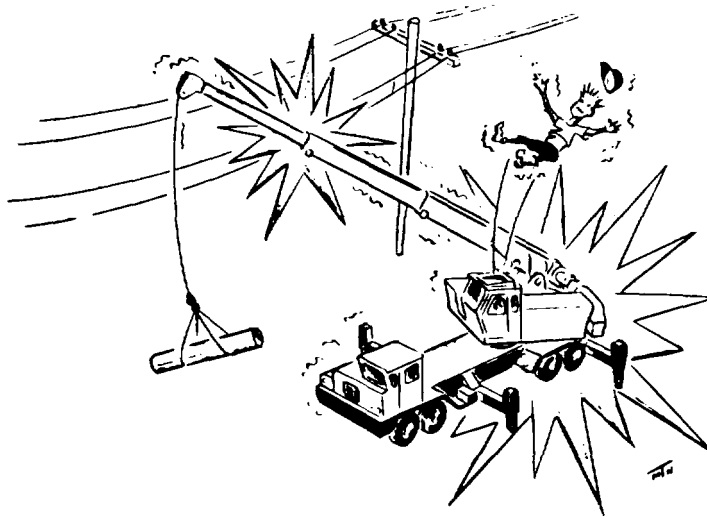

AVOID HIGH WIRE ACTS

**POWER LINE CONTACT IS THE LARGEST SINGLE CAUSE
OF FATALITIES ASSOCIATED WITH CRANES.**

Permit No One to Ride Loads, Slings, Hooks, Etc. Aerial acts are best performed by professional stunt men.

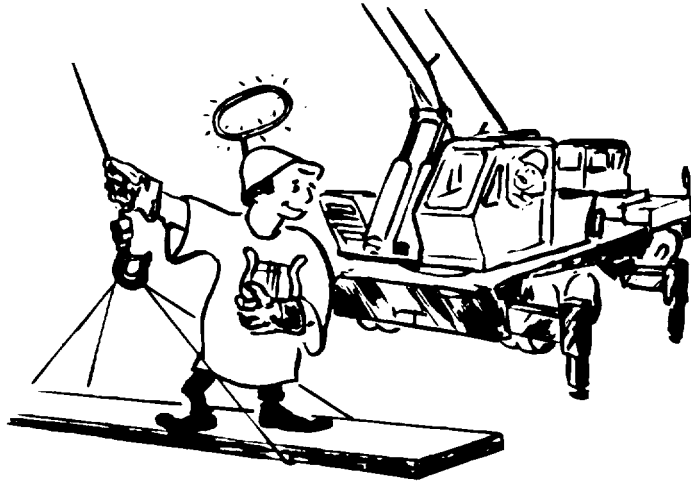

ALLOW NO ONE TO HITCH A RIDE

ALLOW NO ONE TO HITCH A RIDE

Watch Clearances When Traveling. Do not take a chance of running into overhead or side obstructions. When moving in tight quarters, post look-out to help guard against collisions or bumping of structures.

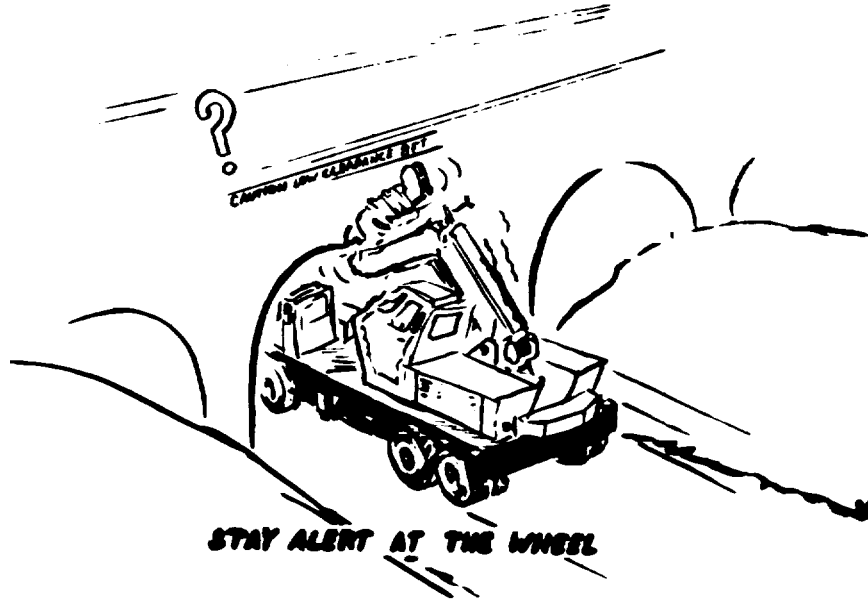

Lift One Load At A Time. Do not lift two or more separately rigged loads at one time, even if loads combined are within rated capacity.

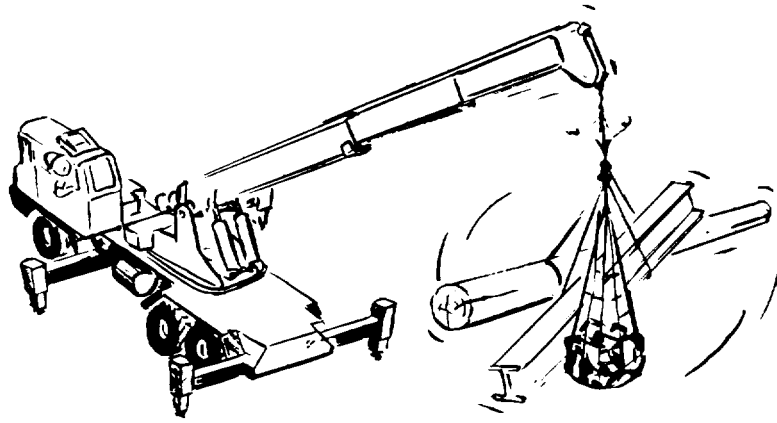

NEVER HANDLE MORE THAN ONE LOAD AT A TIME

NEVER HANDLE MORE THAN ONE LOAD AT A TIME.

Never Swing Over Ground Personnel. Never swing over ground personnel, regardless of whether or not load is suspended from or attached to boom.



BE PEOPLE CONSCIOUS

Never Pull or Push With A Boom. Never pull sideways with boom or use boom as a ram. Crane booms are not designed for side loading.

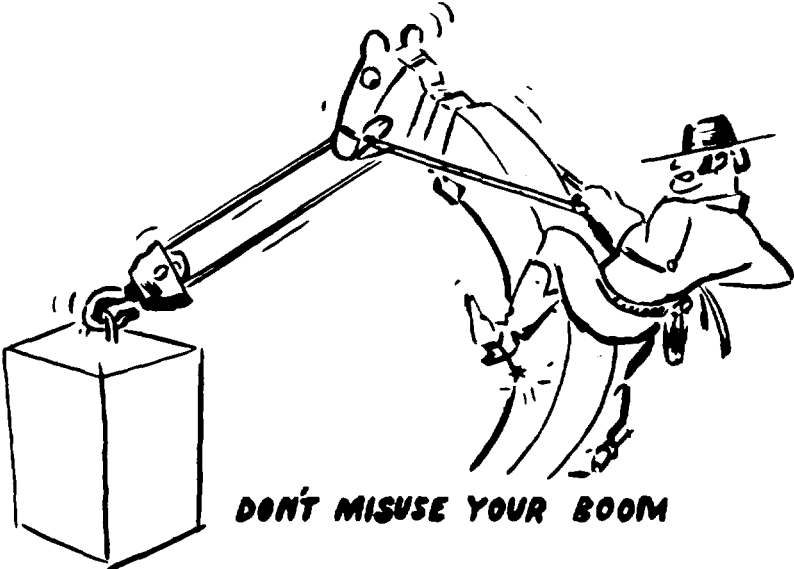

Keep Everyone Away From Suspended Loads. Do not allow personnel or equipment in areas around or under suspended loads.

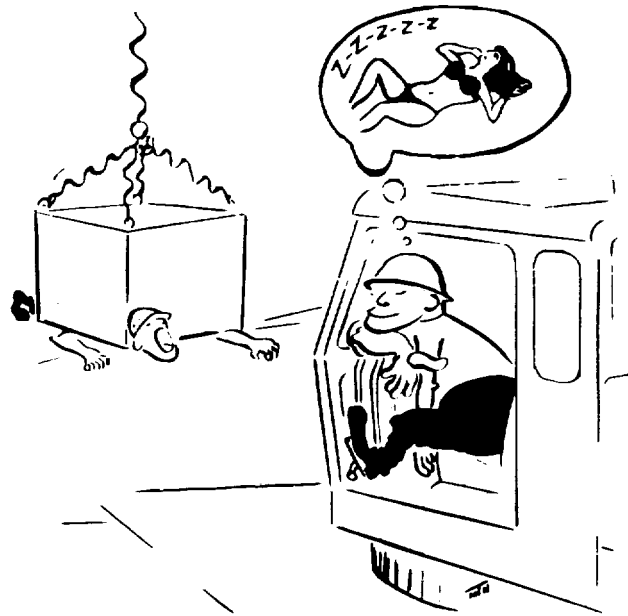

BE ALERT - STAY ALERT

Never Leave Machine With Load Suspended. Do not leave machine with raised load - if you must leave machine - lower load to ground and stop engine before leaving cab.

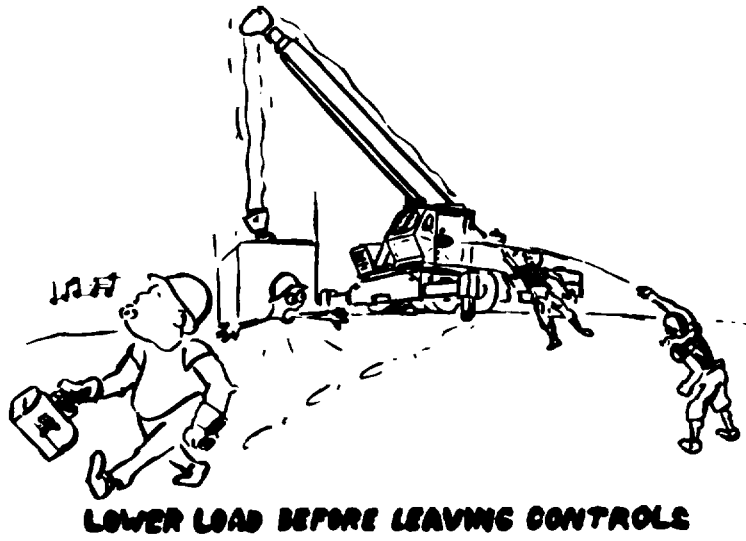

Use Enough Parts of Line for Heavy Lifts and Check All Rigging for Proper Attachment. To obtain maximum lifting capacities, hook block must be rigged with sufficient parts of line. When operating with multi-part reeving, **NO LESS THAN TWO WRAPS** should remain on hoist drum. When slings, ties, hooks, etc., are used, make certain that they are properly positioned and secured before raising or lowering loads.

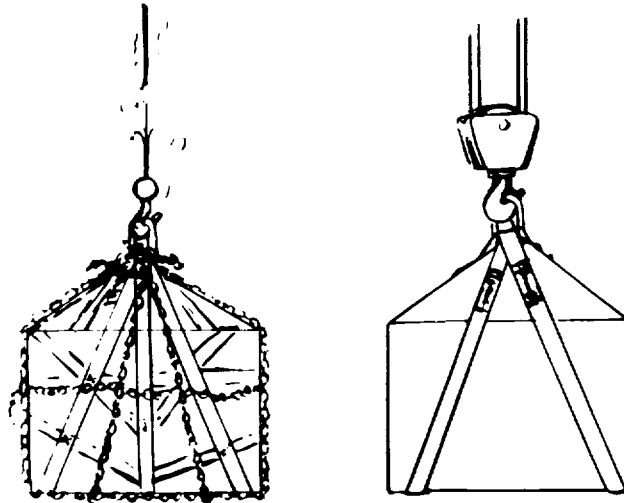

RIG TO SUIT THE LIFT

Check All Braking and Restraining Devices Before Operation. Perform an operational check of all braking (wheel and swing) and safety restraining (tag lines, slings, etc.) devices prior to initiating any crane or traveling operations.

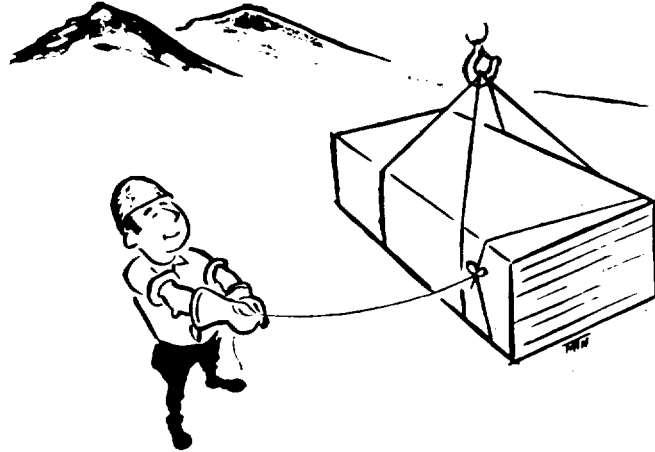

CONTROL LOAD AT ALL TIMES

Keep Your Boom Down. Swinging loads with a long line can create unstable conditions and possible structural failure of the boom.

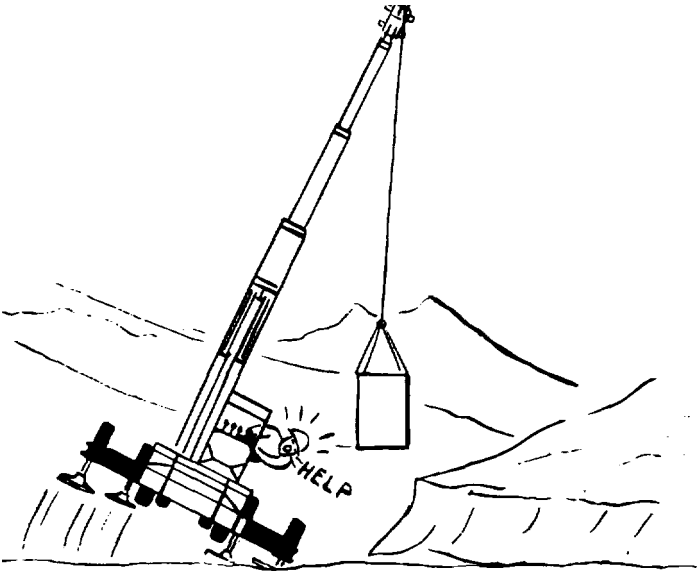

KEEP YOUR BOOM DOWN



BE PREPARED.

1. Know your equipment - prepare it for the job.
2. Know its capability.
3. When planning your operation, don't neglect to consider potential hazards and operating limitations.
4. If operating radius is unknown, plan your loads on the safe side of the load chart.
5. Recognize and understand dangerous situations.
6. Develop instinctive corrective control reaction when suddenly confronted with the unexpected.



DON'T FORGET.

LOAD CHARTS REPRESENT THE ABSOLUTE MAXIMUM ALLOWABLE LOADS WHICH ARE USUALLY BASED ON EITHER 85% OF TIPPING OR STRUCTURAL LIMITATIONS UNDER SPECIFIC CONDITIONS. UNLESS THE PRECISE RADIUS OF OPERATION, BOOM LENGTH AND ANGLE IS KNOWN, ROUTINE PLANNING AND OPERATION SHOULD REMAIN WELL BELOW THESE CAPACITY FIGURES.

DON'T FORGET.

OVER-THE-SIDE LIFTING CAPACITIES APPLY WHEN THE LOAD IS MOVED FROM OVER-THE-REAR TO BEYOND THE CENTERLINE OF THE FRONT AND REAR TIRES WHEN LIFTING ON RUBBER, OR BEYOND THE CENTERLINE OF THE FRONT AND REAR OUTRIGGERS WHEN OPERATING ON OUTRIGGERS.

DON'T FORGET.

IF THE CRANE IS NOT LEVEL, LOAD CAPACITIES ARE REDUCED WHEN LIFTING ON THE LOW SIDE. DON'T BE MISLED BY OPTICAL ILLUSIONS. USE YOUR BUBBLE LEVEL.

DON'T FORGET.

USE CAUTION WHEN STARTING TO LIFT UNKNOWN WEIGHTS - THAT SMALL BOX MIGHT BE FILLED WITH LEAD.

DON'T FORGET.

IF A TIPPING CONDITION IS SUDDENLY SENSED - START LOWERING THE LOAD AND RETRACT OR ELEVATE THE BOOM TO BRING THE LOAD IN. NEVER LOWER THE BOOM AND AGGRAVATE THE CONDITION.

DON'T FORGET.

SUDDEN STOPPING WHEN LOWERING A LOAD CAN EFFECTIVELY INCREASE THE LOADING TO TIPPING OR A STRUCTURAL FAILURE CONDITION.

DON'T FORGET.

EVEN IF A HYDRAULIC LINE MAY BE SHEARED OR BROKEN ON THE LIFT OR EXTENSION CYLINDERS, THE CRANE WILL STILL FUNCTION SUFFICIENTLY TO GET THE LOAD DOWN.

DON'T FORGET.

MAXIMUM LIFTING CAPABILITY IS AVAILABLE AT THE SMALLEST RADIUS, SHORTEST BOOM LENGTH AND GREATEST BOOM ANGLE.

CONTROLS, GAGES AND INDICATORS.

The paragraphs to follow identify the controls, gages and indicators in the Superstructure Cab. Also, the paragraphs specify the purpose of each control, indicator, and gage. The index numbers on the illustrations correspond to the numbers in the paragraphs.

CONTROLS.

1. Swing Control Lever. Allows the boom to rotate 360° in either direction. Lever movement forward causes the boom rotation to the right, and lever movement rearward causes boom rotation to the left.
2. Swing Warning Horn. Used to warn personnel that boom is swinging.
3. Swing Control Treadle. Is attached to the Swing Control Lever. The treadle provides the operator with foot control during swinging operations.
4. Fly Telescope Control Lever. Controls extension of the fly section. Lever movement forward extends the fly section. Lever movement rearward retracts the fly section.
5. Swing Brake Pedal. The swing brake pedal stops boom swing. When the brake pedal is depressed, hydraulic pressure is applied to the swing box brakes. Thus boom swing is stopped in a smooth even manner.
6. Mid Telescope Control Lever. Controls extension of the mid section. Lever movement forward extends the mid section. Lever movement rearward retracts the mid-section.
7. Boom Elevation Control Lever. The lever controls boom elevation. Lever movement forward elevates the boom. Lever movement rearward lowers the boom.
8. Boom Elevation Control Pedal. The pedal is attached to the Boom Control Lever. Thus the operator can control boom elevation with his foot.

- 9 Auxiliary Hoist Control Lever. The lever controls auxiliary hoist operation. Lever movement forward causes the hoist drum to rotate, and cable to unwind. Lever movement rearward causes the hoist drum to rotate and cable to wind.
10. Main Hoist Control Lever. The lever controls main hoist operation. Lever movement forward causes the hoist drum to rotate and cable to unwind. Lever movement rearward causes the hoist drum to rotate and cable to wind.
11. Outrigger Control Panel. The Outrigger Control Panel has control buttons and a selector switch for operation of the outrigger extension cylinders and stabilizers cylinders.
12. Hoist Free Fall Control Valve Levers. When actuated, releases the free fall brake in the main and auxiliary hoists, and allows load to free fall.
- 13 Ignition Switch. When energized provides power to the Superstructure for accessories and starting engine.
- 14 Engine Foot Throttle. Foot operated throttle used to control engine rpm from the Superstructure cab.
15. Engine Hand Throttle. Hand operated throttle used to control engine rpm from the Superstructure cab.
- 16 Engine Stop Switch. When depressed energizes a solenoid to close the governor on the engine to shut down the engine.
17. Lights Switch. Three position switch (center off) used to energize the cab dome light or the front console instrument lights.
18. Wiper Switch. A rotary switch used to control the operation of the windshield wiper.
- 19 Panel Light Switch. A two position switch used to control the right console panel light.
20. Right Console Panel Light. Used to illuminate the right console panel.

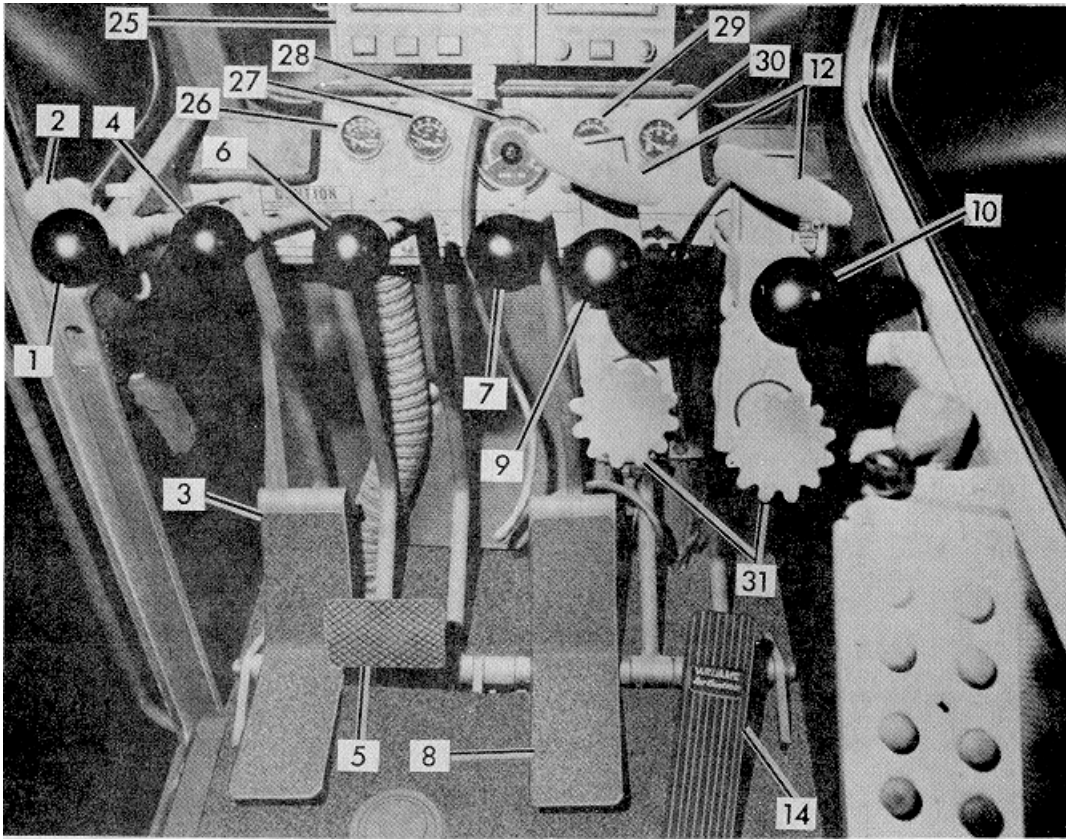

- 1 Swing Control Lever
- 2 Swing Horn Button
- 3 Swing Control Pedal
- 4 Fly Telescope Control Lever
- 5 Swing Brake Pedal
- 6 Mid Telescope Control Lever
- 7 Boom Elevation Control Lever
- 8 Boom Elevation Control Pedal
- 9 Auxiliary Hoist Control Lever
- 10 Main Hoist Control Lever
- 11 Outrigger Control Panel
- 12 Hoist Free Fall Control Levers
- 13 Ignition Switch
- 14 Engine Foot Throttle
- 15 Engine Hand Throttle
- 16 Engine Stop Switch
- 17 Lights Switch
- 18 Wiper Switch
- 19 Panel Light Switch
- 20 Right Console Panel Light
- 21 Floodlights Switch
- 22 Heater Temperature Control Knob
- 23 Heat/Defrost Control Knob
- 24 Heater Control Panel
- 25 Krueger LMI Control Panel
- 26 Water Temperature Gage
- 27 Oil Pressure Gage
- 28 Tachometer
- 29 Voltmeter
- 30 Fuel Gage
- 31 Hoist Rotation Indicators
- 32 Bubble Level Indicator

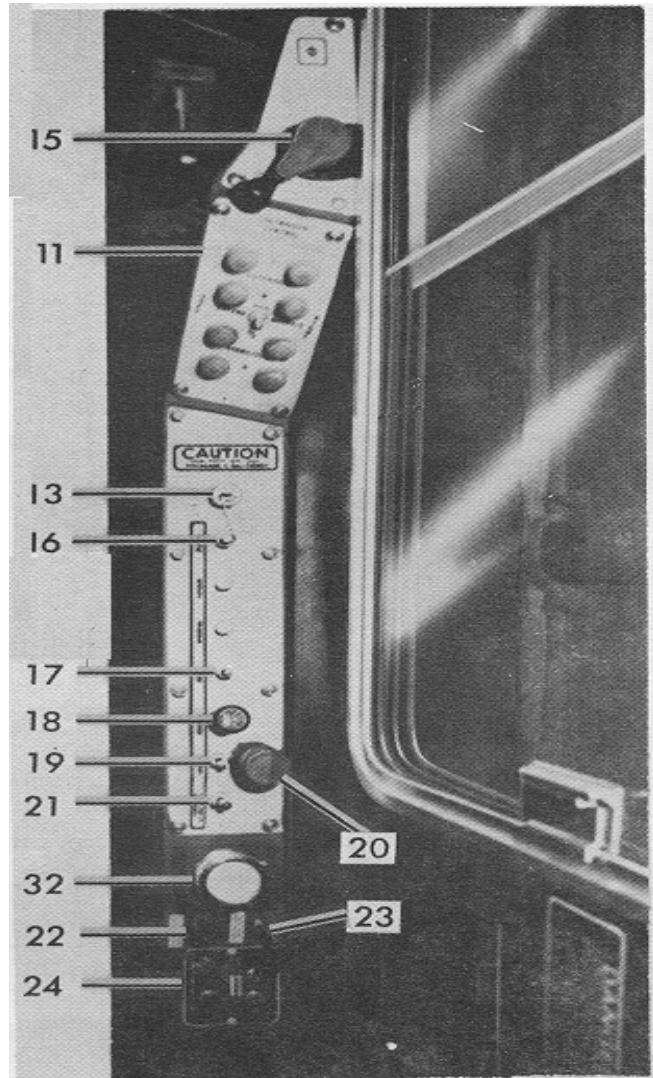

21. Floodlights Switch. A two position switch used to control the floodlights on the boom and the front of the cab.
22. Heater Temperature Control Knob. A push-pull control for controlling the air temperature from the heater. Pull for low temperature and push for high temperature.
23. Heat/Defroster Control Knob. A push-pull control for controlling the mode of operation for the heater. Pull for heat and push for defrost.
24. Heater Control Panel. Provides controls for operation of the fuel oil cab heater.
25. Krueger LMI Control Panel. Provides controls for programming the Krueger LMI system and provides boom angle indication. Mechanical Swing Parking Brake Control Lever. (Not Shown). When applied, locks the swing box by engaging the swing box mechanical brake. Mechanical brake adjustment is accomplished by rotating the control lever knob.

GAGES.

26. Water Temperature Gage. Shows the temperature of the engine coolant.
27. Oil Pressure Gage. Shows the pressure in PSI of the engine oil.
28. Tachometer. Shows the rpm of the engine.
29. Voltmeter. Indicates the battery condition, when alternator is not producing electromotive force (volts). Also, shows condition of the charging system with engine operating.
30. Fuel Gage. Indicates fuel quantity of the tank.

INDICATORS.

31. Hoist Rotation Indicators. Provides the operator with a visual indication of the main and auxiliary hoist drum speed and direction.

32. Bubble Level Indicator. Provides the operator with a visual indication of the level condition of the machine.

Heater On Indicator Light. (Not Shown). A red light located on the front console that provides the operator with a visual indication that the cab heater is in operation.

Ignition On Indicator Light. (Not Shown). A green light located on the front console that provides the operator with a visual indication that the ignition switch is on.

PRE-STARTING INSPECTION.

A complete "walkaround" visual inspection of the machine should always be made with special attention to structural damage, loose equipment, leaks or other conditions that would require immediate correction for safety of operation.

The following "Checklist" items are suggested specifically for the operator's benefit to make certain that his machine is prepared for starting the day's work.

FUEL SUPPLY. Check that fuel tank is full and cap is on tight.

ENGINE OIL. Check oil level in crankcase; fill to proper level - do not overfill.

ENGINE COOLANT. Check coolant level in radiator; fill to proper level do not overfill. Check cap for security.

BATTERIES. Check batteries for proper liquid level, tightness of cable and caps, visible damage, and corrosion. Add only clean distilled water - avoid overfilling.

SIGNAL AND RUNNING LIGHTS. Check all signal and running lights for proper operation. Replace burned out lamps with those of the same number, or equivalent.

FOOT AND PARKING BRAKES. Check for proper operation. Check alcohol evaporator reservoir for fluid quantity. Drain air tanks of accumulated moisture.

TIRES. Check for severe cuts, foreign objects imbedded in treads, and for correct inflation pressures.

HYDRAULIC RESERVOIR AND FILTER. Check hydraulic fluid quantity level gage and check filter condition indicator. Check breather for cleanliness and security.

DAILY LUBRICATION. Make certain that all components requiring daily lubrication have been serviced. (Refer to applicable lubrication chart for specific details).

WIRE ROPE. Visually inspect all wire ropes. Rope conditions requiring evaluation of safety and consideration for replacement are as follows:

1. Corrosion
2. More than one broken wire in any one strand.
3. More than one broken wire near attach fitting.
4. Excessive wear and/or broken wires in rope sections under sheaves where rope travel is limited.
5. Evidence of noticeable reduction in original rope diameter after allowance for normal stretch and diameter reduction of a newly rigged rope.
6. Excessive abrasion, scrubbing and peening of outside wires; pitting, bird-caging (deformation), or other damage resulting in physical changes to the rope structure.
7. Cracked, bent, worn, or improperly installed end connections (wedge socket, turnbuckles, etc.).

Sheaves, guards, guides, drums, flanges, etc., and any other surfaces that come in contact with the rope should be inspected for any condition that could cause possible damage to the rope.

HOOK BLOCK. Visually inspect for nicks, gouges, cracks, and evidence of any other damage. Replace a hook containing cracks or showing evidence of excessive deformation of the hook opening (including twist). Be sure safety latch is free and aligned.

STARTING PROCEDURE.

WARNING

BEFORE STARTING ENGINE, MAKE CERTAIN TRANSMISSION IS IN NEUTRAL, BRAKE APPLIED AND SWING (HOUSE) LOCK ENGAGED.

1. With a cold engine, the initial start should be made from the carrier cab in accordance with the procedures outlined in the carrier operators handbook.
2. Once the engine is warm, shut it down.
3. Ensure the pump drive is engaged.
4. Turn the start switch in the superstructure cab to the starting position. Release immediately when the engine starts.

CAUTION

NEVER CRANK ENGINE FOR MORE THAN 30 SECONDS DURING AN ATTEMPTED START. IF ENGINE FAILS TO START AFTER 30 SECONDS, ALLOW STARTER MOTOR TO COOL FOR APPROXIMATELY TWO MINUTES BEFORE ATTEMPTING ANOTHER START.

IF ENGINE FAILS TO START AFTER FOUR ATTEMPTS CORRECT MALFUNCTION BEFORE ATTEMPTING ANY FURTHER STARTS.

5. After the engine has started, check the instruments for the following indications:

Oil Pressure Indicator. Normal operation 30-60 psi, within 10-15 seconds after start.

Coolant Temperature Indicator. Normal operating temperature 160°F-185°F (71°C-85°C) after engine warm up.

Voltmeter. At least 12 volts.

CAUTION

IF OIL PRESSURE AND/OR TEMPERATURE INDICATOR(S) DO NOT DISPLAY PROPER READINGS, SHUT DOWN ENGINE AND CORRECT MALFUNCTION BEFORE RESUMING OPERATION.

6. Allow the engine to idle at least five minutes giving the hydraulic oil time to warm up.

SHUTDOWN PROCEDURE.

1. Operate the engine at fast idle for approximately five minutes to avoid high internal heat rise and allow heat dissipation.
2. Position the ignition switch to off.
3. Depress the engine stop button.

EMERGENCY SHUTDOWN.

When the engine will not stop using the regular SHUTDOWN PROCEDURE, use the emergency shutdown knob. This knob is located in the carrier cab. After the engine has stopped, the shutoff valve must be reset before the engine can be restarted (see the CARRIER OPERATORS HANDBOOK).

CAUTION

CORRECT THE MALFUNCTION THAT REQUIRED THE EMERGENCY SHUTDOWN BEFORE RESUMING OPERATIONS.

CRANE FUNCTIONS.

OUTRIGGER OPERATION.

Setting the Outriggers. To set the outriggers, first the applicable outrigger control button(s) is/are depressed, then the MAIN OUTRIGGER CONTROL switch is positioned to EXTEND.

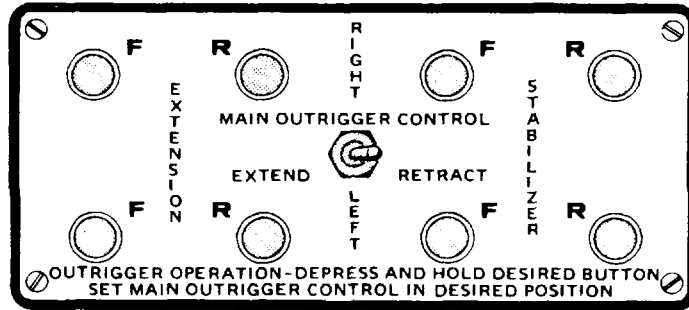

WARNING

WHEN OPERATING WITH OUTRIGGERS EXTENDED AND DOWN, ALL WEIGHT MUST BE OFF THE WHEELS WITH OUTRIGGERS SUPPORT-ING MACHINE.

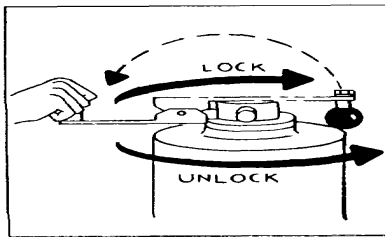

ENSURE ALL FOUR LOCKS ARE DOWN ALL THE WAY BEFORE LIFTING LOAD.

CAUTION

BEFORE INITIATING STOWING OPERATIONS, ASSURE THAT ALL SPIN-LOCKS ARE ALL THE WAY UP.

Stowing the Outriggers. To stow the outriggers, first the applicable outrigger control button(s) is/are depressed, then the MAIN OUTRIGGER CONTROL switch is positioned to RETRACT.

CONTROL LEVER OPERATION.

Control lever operation for crane functions is standard, i.e., the closer the lever is to neutral (center), the slower the system operates and the further the control is from neutral the faster the operation.

To provide multiple crane function capability, foot treadles are integral with swing and boom control levers.

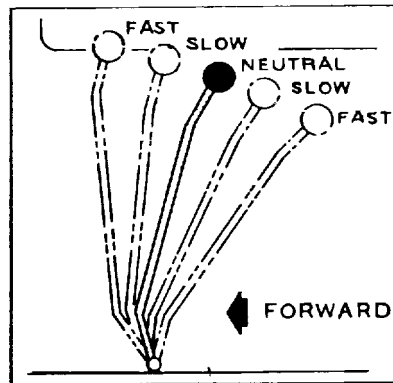

SWINGING THE BOOM.

To swing boom, SWING control lever is "pushed forward", away from operator, for RIGHT swing and "pulled back", toward operator, for LEFT swing. Always operate control lever or treadle with a smooth, even pressure movement.

CAUTION

BOOM MUST ALWAYS BE ELEVATED FROM BOOM REST BEFORE SWING OPERATION.

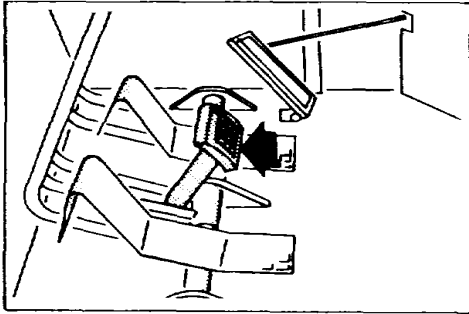

Swing Foot Brake.

NEVER PUSH OR PULL CONTROL LEVER THROUGH NEUTRAL TO OPPOSITE DIRECTION TO STOP SWING MOTION; USE SWING FOOT BRAKE IN CONJUNCTION WITH CONTROL LEVER TO STOP OR SLOW DOWN SWING.

MAKE CERTAIN THAT SWING (HOUSE) LOCK AND SWING PARKING LOCK IS IN UNLOCKED POSITION PRIOR TO INITIATING ANY SWING OPERATIONS.

WHEN SWINGING LOAD FROM OVER-THE-REAR TO OVER-THE-SIDE OF MACHINE, REFER TO OVER-THE-SIDE LOAD CHART TO MAKE CERTAIN THAT APPLICABLE CAPACITY IS, NOT EXCEEDED.

ELEVATING AND LOWERING THE BOOM.

WARNING

BEFORE ELEVATING BOOM, MAKE CERTAIN THAT AREA ABOVE AND BENEATH BOOM IS CLEAR OF ALL OBSTRUCTIONS AND PERSONNEL.

Elevating the Boom. To elevate boom, BOOM control lever or foot treadle is "pulled back" toward operator, to UP position and held until boom reaches desired elevation angle. An interconnected floor treadle provides foot operation capability.

Lowering the Boom. To lower boom, BOOM control lever or foot treadle is "pushed forward", away from operator, to DOWN position and held until boom is lowered to desired position.

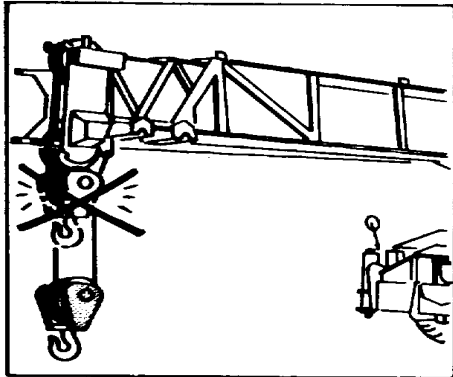

CAUTION

WHEN LOWERING BOOM, LET OUT CABLE SIMULTANEOUSLY TO PREVENT TWO-BLOCKING BOOM NOSE AND HOOK BLOCK.

THE CLOSER THE LOAD IS CARRIED TO BOOM NOSE, THE MORE IMPORTANT IT BECOMES TO SIMULTANEOUSLY LET OUT CABLE AS BOOM IS LOWERED.

WARNING

BEFORE LOWERING BOOM, MAKE CERTAIN AREA BENEATH BOOM IS CLEAR OF ALL OBSTRUCTIONS AND PERSONNEL.

LONG CANTILEVER BOOMS CAN CREATE A TIPPING CONDITION WHEN IN EXTENDED AND LOWERED POSITIONS. RETRACT BOOM PROPORTIONALLY WITH REFERENCE TO CAPACITY OF APPLICABLE LOAD CHART.

EMERGENCY PROCEDURE: ALTHOUGH HIGHLY IMPROBABLE IF PROPER MAINTENANCE AND FREQUENT INSPECTIONS ARE ACCOMPLISHED, THERE REMAINS THE POSSIBILITY THAT THE HYDRAULIC EQUALIZER LINE COULD FAIL. IF THIS OCCURS THERE ARE RESTRICTING DEVICES PROVIDED THAT WILL ALLOW CONTINUED OPERATIONS OF THE CRANE. ALL CRANE FUNCTIONS

REMAIN OPERABLE UNTIL THE HYDRAULIC OIL IN THE RESERVOIR IS DEPLETED.

RECOMMENDED PROCEDURE FOR OPERATING THE CRANE IF THE EQUALIZER LINE FAILS IS AS FOLLOWS.

1. Remain at operator's station as all functions can be accomplished.
2. Accelerate engine to normal operating RPM.
3. Maintain boom attitude (elevation) by activating boom elevation control. While holding boom at desired attitude, activate swing, retract telescoped sections, operate hoist, as necessary, until load is safely lowered to ground.

TELESCOPING THE BOOM.

CAUTION

POWER TELESCOPING SECTIONS MUST BE EXTENDED EQUALLY AT ALL TIMES TO COMPLY WITH LOAD CHART MAXIMUM LIFTING CAPACITIES.

WHEN EXTENDING BOOM, LET OUT CABLE SIMULTANEOUSLY TO PREVENT TWO-BLOCKING BOOM NOSE AND HOOK BLOCK.

CHECK LOAD CHART FOR MAXIMUM LOAD AT GIVEN RADIUS, BOOM ANGLE AND LENGTH BEFORE EXTENDING BOOM WITH A LOAD.

Extending the Boom. To extend boom, TELESCOPE section control levers are "pushed forward" away from operator, to OUT position and held until boom sections extend to desired length.

WARNING

WHEN RETRACTING BOOM, LOAD WILL LOWER UNLESS CABLE IS TAKEN IN SIMULTANEOUSLY.

Retracting the Boom. To retract boom, TELESCOPE section control levers are "pulled back", toward operator, to IN position and held until boom retracts to desired length.

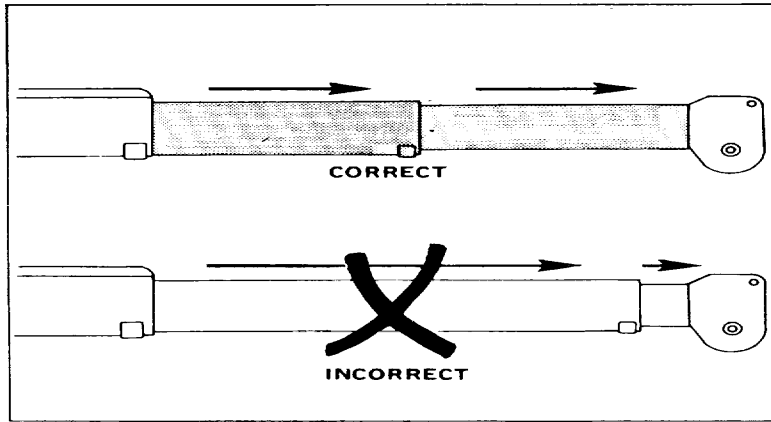

Proper Boom Telescoping.

LOWERING AND RAISING THE CABLE.

CAUTION

WHEN STARTING OR STOPPING HOIST, DO NOT JERK CONTROL LEVER. JERKING LEVER CAUSES LOAD TO BOUNCE, WHICH COULD RESULT IN POSSIBLE DAMAGE TO MACHINE.

NOTE

CONTROL LEVER DISTANCE FROM NEUTRAL (CENTER) DETERMINES HOIST LINE SPEED.

WHEN LOAD IS STOPPED AT DESIRED HEIGHT, THE AUTOMATIC BRAKE WILL ENGAGE AND RETAIN LOAD AS LONG AS CONTROL LEVER REMAINS IN NEUTRAL.

WARNING

BEFORE LOWERING OR RAISING CABLE (LOAD) ASSURE THAT AREA BENEATH LOAD IS CLEAR OF ALL OBSTRUCTIONS AND PERSONNEL.

Lowering the Cable. To lower the cable, the HOIST control lever is "pushed forward", away from the operator, to the DOWN position and held until hook or load is lowered to desired height.

Raising the Cable. To raise the cable, the HOIST control lever is "pulled back", toward the operator, to the UP position and held until hook or load is raised to desired height.

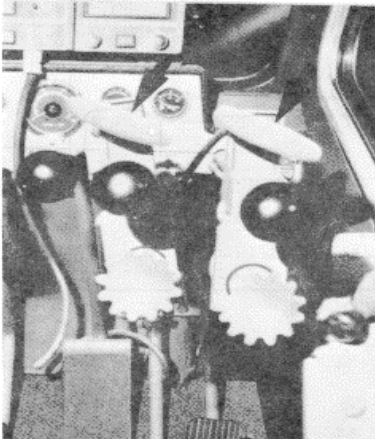

HOISTFREE FALL This feature provides faster lowering of the cable than can be obtained by power operation. A finger actuated pull control is mounted on the hoist control lever for convenient and easy transition from normal operation.

Free fall operation should be practiced with very light loads and short falls until a feel for the operation is developed. Smooth and gradual snubbing of loads is necessary to avoid high shock loads. **Free fall loads are limited to a maximum of 2845 lbs. or 30% of the load chart capacity, whichever is less.**

Hoist free fall is normally used only for lowering concrete buckets, fast return of empty hooks or emergency release of loads.

PRELOAD OPERATION CHECK.

After the machine has been readied for service, an operational check of all crane functions (with no load applied) should be performed. Accomplish the Preload Check as follows:

CAUTION

OPERATE ENGINE AT OR NEAR GOVERNED RPM DURING PERFORMANCE OF ALL CRANE OPERATIONS.

NOTE

CAREFULLY READ ALL CRANE OPERATING INSTRUCTIONS BEFORE ATTEMPTING "PRELOAD CHECK" AND OPERATING MACHINE UNDER LOAD.

1. Raise boom from rest and swing to over rear.
2. Raise, lower, and swing boom right and left a minimum of 45 degrees.
3. Telescope boom in and out; be sure to extend and retract sections proportionally.
4. Raise and lower cable a few times at various boom lengths, making certain that there is no kinking.

HANDLING THE LOAD.

Safety of the operator and ground personnel holds top priority in load handling operations. The following safety guidelines should take precedence with the operator.

CAUTION

NEVER PERFORM LIFTING OPERATIONS WITH BOOM IN "OVER-THE-FRONT" POSITION.

1. Do not lift a load if machine is not level and firmly positioned on properly extended outriggers.
2. Make certain that the area around and beneath load is clear, and kept clear, of all obstructions and personnel.
3. Always use proper chains or slings applicable to type of load.
4. Make certain that all ground crew personnel are wearing approved head gear.
5. Long cantilever booms can create a tipping condition when in extended and lowered positions. Extend and retract boom proportionally with reference to capacity of applicable load chart.
6. Refer to applicable capacity load chart before lifting loads.
7. When operating with single or multi-part line, no less than two wraps should remain on hoist drum.

The operator should also be aware of the following important precautions in order to avoid subjecting his machine to undue stresses and loads.

1. DO NOT perform any crane operations with engine at idle. Operate engine at specified rpm during performance of ALL operations.
2. Always keep load as close to crane and ground as possible when swinging boom.
3. Keep distance between boom nose and load as short as possible to prevent excessive load swing.
4. NEVER lift load with lift cylinders fully retracted (bottomed).
5. When lowering or extending boom, let out cable simultaneously to prevent two-blocking boom nose and hook block.
6. Always operate crane control levers with smooth, even pressures; never jerk a control lever.
7. Never suddenly release a control lever to stop a function. Always return lever to neutral in smooth, even manner.

TRAVELING WITH A LOAD.

WARNING

ONLY MACHINES WITH PUBLISHED "ON RUBBER" CAPACITIES ARE PERMITTED TO TRAVEL WITH A LOAD.

CAUTION

ONLY TRAVEL WITH A LOAD ON FIRM LEVEL SURFACES AND DO NOT EXCEED 2.5 MPH (4 KM/H).

All load chart capacity ratings are based on the crane being level and in a stationary position. Traveling with suspended loads entails many variables, i.e., the type of terrain, boom length and angle, momentum in starting and stopping, etc. Due to these factors, it is impossible to formulate a single standard rating procedure with any assurance of safety. Thus, before traveling with a load, it is the operators responsibility to evaluate the conditions and determine the necessary safety precautions. The following general precautions should be taken at all times.

1. Position boom over the rear of carrier.
2. Engage swing set (house) brake.
3. Govern travel speed suitable to existing conditions.
4. Maintain correct tire pressures.
5. Avoid sudden starting and stopping.
6. Provide tag or restraint lines to snub load swing.

ERECTING AND STOWING 32 FT. SWINGAWAY EXTENSION -

Erecting 32 Ft. Swingaway Extension. Erect 32 ft. swingaway extension in accordance with the following procedure.

1. Extend and set outriggers.
2. Swing boom over rear of carrier.
3. Fully retract boom if extended, and lower below horizontal (4 degrees).
4. Rig cable for single part line operation.
5. Assure the cable dead head is in stowed position, and release latch securing extension to aft bracket on side of boom.

WARNING

DO NOT DETACH EXTENSION FROM MAIN BRACKET AT THIS TIME.

6. With main bracket acting as pivot, pull outward on extension tip to position anchor fittings in extension attach fittings on right side of boom nose.
7. Secure extension to right side of boom nose with attach pins; secure attach pins with safety pins.

NOTE

EXTENSION ATTACH PINS ARE STOWED ON SUPPORTS AT BASE OF 32 FT. SECTION.

8. Remove safety pins from attach pins securing extension to main bracket on side of boom; remove attach pins.
9. Elevate boom to horizontal, and swing extension into place ahead of boom nose, engaging anchor fittings with extension attach fittings on left side of boom nose.
10. Secure extension to left side of boom nose with attach pins; secure attach pins with safety pins.
11. Let out cable and route over extension sheave; attach hook. Extension is now ready for single line operation.
12. For two-part line operation, reeve cable under hook block sheave, attach becket and secure to anchor on extension tip.

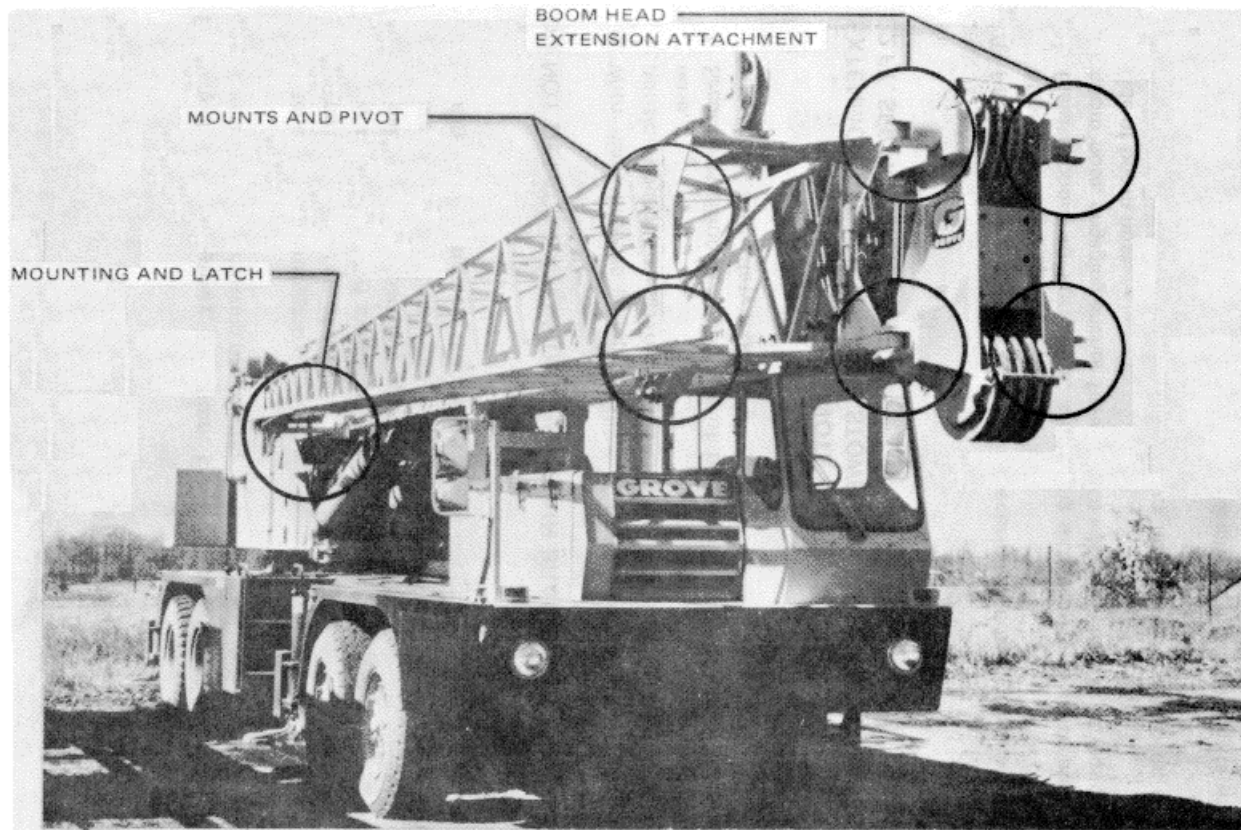

Swingaway Boom Extension

Stowing 32 Ft. Swingaway Extension. Stow 32 ft. swingaway extension in accordance with the following procedure.

- .1. Retract, swing and lower boom over rear of carrier below horizontal (-4 degrees).
2. Remove hook from cable; remove cable from jib and stow dead head.
3. Remove safety pins from jib attach pins on left side of boom nose; remove attach pins.
4. Elevate boom to horizontal, and swing jib around to right side of boom base section.
5. Secure jib to main bracket with attach pins; secure attach pins with safety pins.
6. Remove safety pins from jib attach pins on right side of boom nose, remove and stow attach pins.
7. Push jib tip against boom base; engage aft bracket and latch. Jib is now stowed.
8. Rig boom nose as desired.

COUNTERWEIGHT REMOVAL.

- 1 Fully extend and set the outriggers.
- 2 Ensure the boom is fully retracted and at full elevation.
- 3 Swing to the over the rear position.
- 4 The counterweight removal control lever is located on the left hand side of the machine in the rearmost compartment. Raise or lower the counter- weight slightly until the mounting pins can be removed.
- 5 Lower the counterweight to the carrier deck.
- 6 Release the removal cable from the counterweight.
- 7 Raise the removal cable using the control lever.
- 8 Swing over the front.
- 9 Ensure the boom nose is directly over the counterweight.
10. Attach a suitable sling or lifting brackets on the counterweight assembly.
11. Ensure the hook block is rigged with enough parts of line.
12. Attach the hook block to the counterweight.
13. Raise the load and swing over the side and lower the load to the ground.

COUNTERWEIGHT INSTALLATION.

- 1 Fully extend and set the outriggers.
- 2 Ensure the boom is fully retracted and at full elevation.
- 3 Swing to the over the side position.
- 4 Position the counterweight directly under the boom nose.
- 5 Attach a suitable sling or lifting brackets on the counterweight assembly.
- 6 Ensure the hook block is rigged with enough parts of line.
- 7 Attach the hook block to the counterweight.
- 8 Raise the load sufficiently to clear the carrier deck and swing carefully to the over the front position.
- 9 Lower the counterweight on the pads.
10. Remove the slings or lifting brackets and swing to the over the rear position.
11. Lower the removal cable and attach it to the counterweight.
12. Carefully raise the counterweight until the mounting holes align and the mounting pins can be inserted.

INSTALLING CABLE ON HOIST.

CAUTION

IF CABLE IS WOUND FROM STORAGE REEL ONTO HOIST DRUM, REEL SHOULD BE ROTATED IN SAME DIRECTION AS HOIST.

NOTE

CABLE SHOULD PREFERABLY BE STRAIGHTENED PRIOR TO INSTALLATION ON HOIST.

Install cable on hoist drum in accordance with the following procedure.

1. Position cable over boom nose sheave and route to hoist drum.
2. Position hoist drum with cable anchor slot on top.

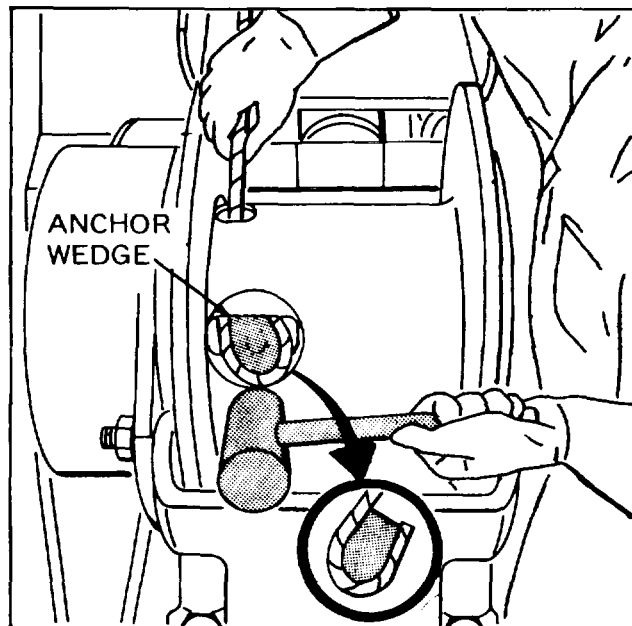

Installing Cable on Hoist.

3. Insert cable through slot and position around anchor wedge.

NOTE

END OF CABLE SHOULD BE EVEN WITH BOTTOM OF ANCHOR WEDGE.

4. Position anchor wedge in drum slot; pull firmly on free end of cable to secure wedge.

NOTE

IF WEDGE DOES NOT SEAT SECURELY IN SLOT, CAREFULLY TAP TOP OF WEDGE WITH MALLET.

CRANE TRAVELING.

PREPARATION FOR TRAVEL.

1. Fully retract the boom and firmly position it in the boom rest.
2. Engage the swing (house) lock.
3. If the machine is rigged, attach the hook block to the snubber line attached to the carrier tow rings.
4. Tighten the cable sufficiently to prevent excessive hook and cable movement during travel.

NOTE

DO NOT TRAVEL WITH THE HOOK IN A POSITION WHERE IT CAN SWING FREELY.

5. Fully retract the outrigger jacks and beams.
6. Remove the jack floats. Stow and secure.
7. Make the final inspection to make certain no loose equipment has been overlooked. Close and secure all compartments.

CAUTION

PUMP DRIVE MUST ALWAYS BE DISENGAGED BEFORE TRAVEL.

LUBRICANTS.

HYDRAULIC OIL.

Two important factors in selecting an oil are:

1. antiwear additives - The oil selected must contain the necessary additives to insure high antiwear characteristics and excellent chemical stability;
2. viscosity - The oil selected must have proper viscosity to maintain a lubricating film at system operating temperature.

Industrial grade antiwear type hydraulic oils should be used. These oils contain additives specifically designed for hydraulic systems.

New machines come from the factory with Sun 2105 (5W20) hydraulic oil.

This oil facilitates start up at temperatures down to 5°F. and is satisfactory up through normal operating temperatures. When replenishment of hydraulic oil becomes necessary, SAE 10W oil with 0.6% zinc dithiophosphate, which is readily available on the open market, may be used. SAE 10W with this additive is compatible with factory installed oil. However, if 100% replenishment is necessary and a SAE 10W oil with appropriate additives is used, start up temperature is raised to 10 F. Extremes of either hot or cold temperatures must be considered on an individual basis. Consult factory for specific recommendations regarding oil viscosity, special equipment, and operating procedures. Regardless of temperature and oil viscosity, always use suitable start-up procedures to ensure adequate lubrication during system warm-up.

Oil viscosity is important because it has a direct bearing on efficient transmission of power. An oil must flow readily through the system with a minimum of pressure and flow loss. Positive lubrication depends on viscosity. The oil must be sufficiently light to get between the components machined surfaces and still maintain a lubricating film at system operating temperatures. Oil too light may cause the following conditions in the systems:

1. excessive leakage;
2. lower volumetric efficiency of the pump;
3. increased component wear;
4. loss of system pressure;
5. lack of positive hydraulic control;
6. lower overall efficiency.

Oil too heavy may cause the following conditions in the system:

1. system pressure drop;
2. increased system temperature;
3. sluggish system operation;
4. low mechanical efficiency;
5. higher power consumption.

Excessive wear in the system may cause a loss in volumetric efficiency, and may cause shutdowns for maintenance. An efficient antiwear oil protects the components against rusting.

Selection of the proper oil is a requirement for satisfactory system performance.

This page intentionally left blank.

LUBRICATION CHART AND SCHEDULES.

Lubrication charts and schedules represent average crane operation. Each owner/operator must determine his own schedule for his specific equipment and type of usage.

It will be noted that many items and lube points common to all equipment are not listed. Analysis and judgment of what is required for proper servicing, has no substitute.

It is of utmost importance that highly loaded components such as boom pivot shafts, lift cylinder cross shafts and all sheave bearings be given special attention.

IMPORTANT

RECOMMENDED LUBRICANT GRADES ARE THOSE CONSIDERED SATISFACTORY FOR MODERATE TEMPERATURES. USER AND SUPPLIER EXPERIENCE IN AREAS OF EXTREME AMBIENT TEMPERATURES WILL TAKE PRECEDENCE IN LUBRICANT SELCTION.

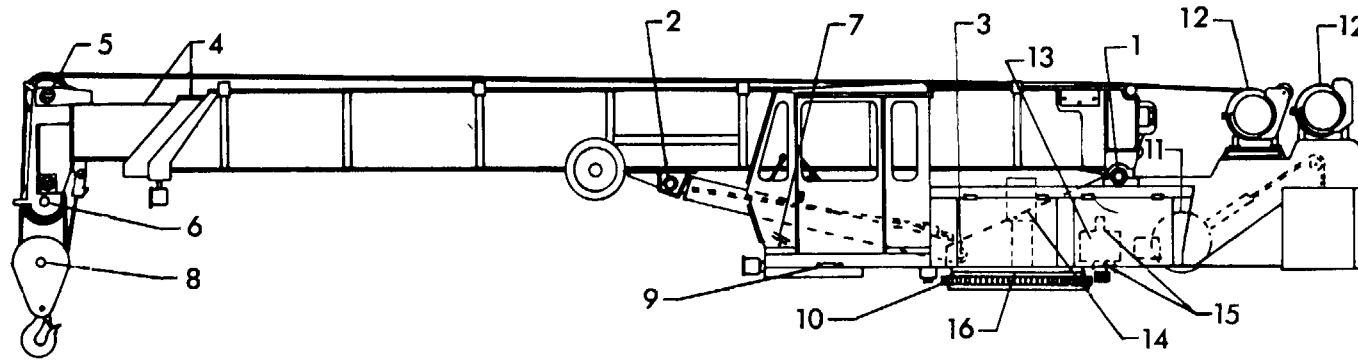

KEY TO LUBRICATION TYPE

CG	Chassis Grease	EPGL	Extreme Pressure Gear Lube SAE 90
EP	Heavy Duty Extreme Pressure Mill Type	OG	Open Gear Lube
HBF	Hydraulic Brake Fluid 70-R1	MO	Motor Oil
HO	Hydraulic Oil - SAE 10 MS		

1NO.	LUBRICATION PERIODS	QUANTITY & FITTING	LOCATION & INSTRUCTIONS	LUBE TYPE
1 2 3	ONCE DAILY Boom Pivot Lift Cylinders (top) Lift Cylinders (base)	2 SAE Std Grease 4 SAE Std Grease 4 SAE Std Grease	1 on top of each pivot/anchor shaft trunnion block 2 on each rod end shaft housing 2 on each base end shaft housing	EP EP EP
4	EVERY 50 OPERATING HOURS Boom Sections	NONE	NOTE: ALL TELESCOPING BOOM SECTIONS SHOULD BE EXTENDED AND COATED WITH GREASE - SIDES AND BOTTOM OR BOTTOM PLATES	EP EP
5 6	Boom Nose Idler Sheave Boom Nose Sheaves	1 SAE Std Grease 3 SAE Std Grease	1 on sheave hub 1 on each end of shaft 1 center of shaft (thru access hole)	EP EP
7	Swing Brake Pedal	1 SAE Std Grease	1 underneath front of cab floor - reached from outside cab	CG CG
8 9	Hook Block Sheave Swing Brake Master Cylinder	1 SAE Std Grease Fill (cap)	1 on sheave hub Underneath front of cab floor - reached from outside cab	HBFB EP
10 11	Turntable Bearing Hose Reel	2 SAE Std Grease 1 Access hole	2 tubes, right hand side Left side of hose reel, saturate spring with motor oil sprayed under pressure	MO EP
12 13	Cable Rollers Swing Box Gear Case	1 SAE Std Grease 1 Level/Fill (pipe plug)	1 on the right hand side Check/fill oil level to bottom of oil level plug	EP EPGL
	CHANGE WHEN DIRTY OR CLOUDY Hydraulic Oil Reservoir	1 Fill (cap) 1 Drain (plug) Hydraulic Oil	Right hand side of carrier	HO
14 15 16	EVERY 100 OPERATING HOURS Electrical Collector Swing Box Bearing Turntable Pinion Gear and Bull Ring Gear	1 SAE Std Grease 1 SAE Std Grease NONE	Under the cover for the electrical swivel 1 top and bottom of swing box case Swing boom over the side and coat gear with lubricant	EP EP OG
13	EVERY 12 MONTHS Swing Box Gear Case	1 Level/fill (pipe plug) 1 drain plug	Change oil	EPGL

This page intentionally left blank.

PART III

**OPERATORS
HANDBOOK**

CONTRACT NO. DSA700-77-C-8511

**KRUGER
LOAD MOMENT SYSTEM
MARK IM**



CAUTION NOTE

ANY OPERATION BEYOND RATED CAPACITY OR THE IMPROPER USE OR APPLICATION OF THE PRODUCT OR THE SUBSTITUTION UPON IT OF PARTS NOT APPROVED BY THE MANUFACTURER SHALL VOID MANUFACTURER'S LIABILITY FOR DIRECT, INDIRECT OR CONSEQUENTIAL DAMAGES RESULTING!

1. FOREWORD

This handbook describes the principles and basic operation of the Krueger Load Moment Indicating System. The purpose of this handbook is to aid the crane operator in recognizing conditions where structural failure or loss of stability of the crane might result.

The Krueger System installed on this crane is the result of many years of design and field performance experience. It represents the highest "State of the Art" available to date.

While the System will sense and alert the Operator to impending overload conditions, IT MUST ALWAYS BE REMEMBERED the System utilizes a series of electrical, mechanical and hydraulic components and CANNOT BE 100 % FAIL-SAFE. Accordingly, Operators and Job-Site Personnel are warned NOT TO CONSIDER THE SYSTEM a substitute for GOOD JUDGMENT, EXPERIENCE AND ACCEPTED SAFE CRANE OPERATING PRACTICES.

Certain programming of the Krueger System is necessary before performing each lift. If incorrectly programmed, the System will not sense and alert the Operator to an impending overload condition, therefore, the contents of this handbook should be read and thoroughly understood before attempting to operate the crane.

This page intentionally left blank,

2. THE KRUGER LMI SYSTEM

What it is -

1. An electro-mechanical sensing system developed to indicate approaching manufacturers maximum rated lifting capacities.

What it does -

By programming with mode selector switch it-

1. Monitors
Load moment
Boom angle
Lift cylinder pressure
2. Electronically compares actual load moment to rated load moment.

Within the system it -

1. Continually measures boom length.
2. Continually senses boom angle in respect to the horizontal.
3. Senses the position of the crane boom in relation to the front center of the crane chassis (working area).
4. Electrically duplicates the manufacturers rated working loads for the crane (lifting capacity chart).

The System then.

1. Integrates the programmed electrical inputs from boom length, working position, boom angle and boom lift cylinders hydraulic pressure, and compares this data to the manufacturers rated lifting capacity for identical operating conditions (electrical duplicate of the lifting capacity chart) and in the event of a no overload of the crane, displays the relative load moment on the operator's console or-
2. Should the combined inputs indicate an overload condition, the system activates an audi-visual alarm.

ADDITIONS

1. Working Range Selection

It senses the position of the crane boom in relation to the front center of the crane chassis (working area). In case there are varying capacity charts for different working ranges an automatical change from one range to the other is given.

If there is a prohibited working range an alarm light will come on and the horn will sound at any time the crane swings out of the permissible working area.

2. Angle Preset

For a specific condition, a working range in dependence on boom or luffing jib angle is settable by this equipment.

If the maximum actual angle is higher or the minimum angle is lower than the setted one the alarm light will come and the horn will sound.

Setup of a KRUEGER Load-Moment-Device System Mark I M for Hydraulic Cranes

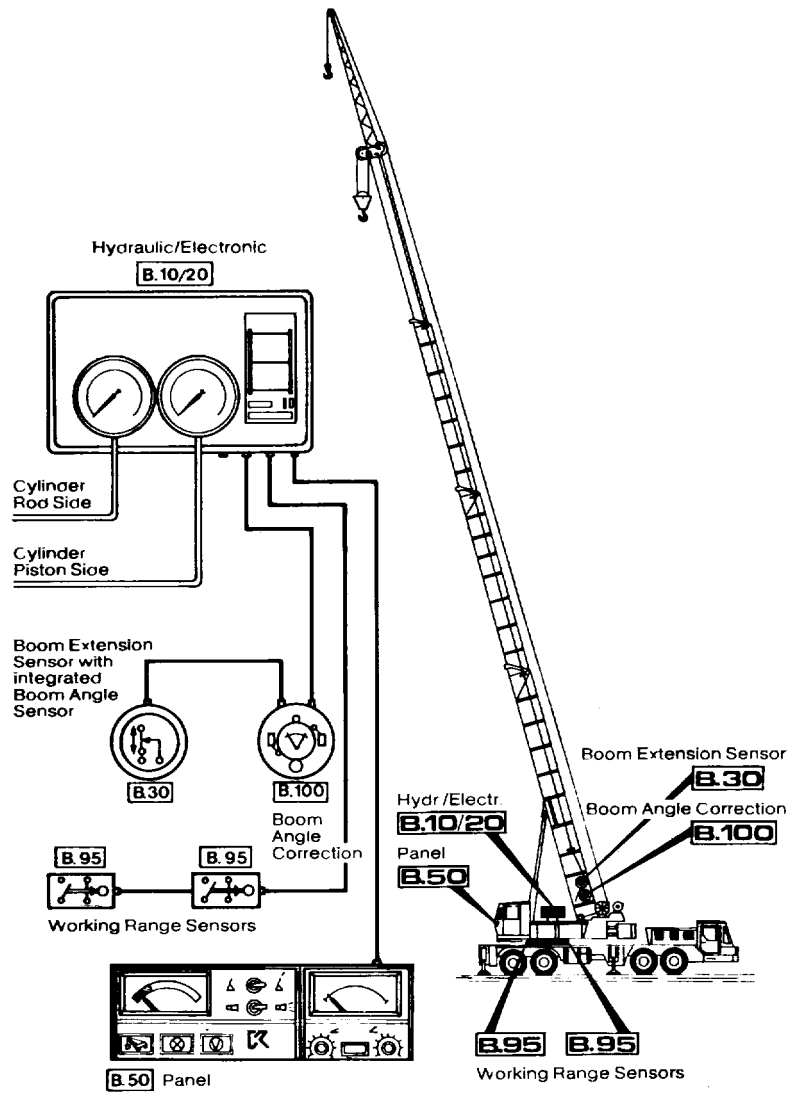

3. DESCRIPTION OF COMPONENTS

1. The Cable Reel (B 30)

Boom length is measured by rope attached to the boom nose. This cable is wound on a spring loaded reel mounted on the base boom section.

The cable reel rotation mechanically drives an electrical variable resistance (potentiometer) that transmits boom length correction signal to the bridge amplifier circuit.

Boom angle is sensed by a pendulum which is an integrated part of the cable reel. It drives a variable resistance (potentiometer) that transmits boom angle information to the boom angle meter and to the bridge amplifier circuit.

2. The Hydraulic System (B 20)

Two pressure gages that separately measure hydraulic pressures at the piston (right manometer) and rod ends (left manometer) of the lift cylinders are used to drive potentiometers that transmit cylinder pressure information to the bridge amplifier circuit.

3. The Electronic (B 10)

The electronic consists, apart from the standard elements (printed circuit plate, fuse, etc.), of the 3 vertically placed program cards and is an integrated part of the Hydraulic System.

4. Boom Angle Correction (B 100)

Boom angle is sensed by a pendulum mounted by the boom base section which drives a variable resistor (potentiometer) that transmits boom angle correction information to the bridge amplifier circuit.

5. The Panel (B 50)

This control unit is located in the operator's cab.

It contains

- load moment meter
- boom angle meter
- program selection switch
- switch for horn
- signal lights
- warning horn
- angle preset system

The correct switch position **MUST** be selected by the operator or a possible incorrect rating condition will result. The left meter indicates total load moment. It is divided into three separate color-coded segments GREEN, YELLOW, and RED representing APPROVED, CAUTION, and PROHIBITED, respectively. When the load moment indicator shows RED, further boom extension, boom lowering and hoisting up is prohibited.

Indication of the right indicator is boom angle. At preset for angle range selection the right of the two rotating knobs can be set at the maximum desired, required or imposed boom angle and the left knob can be set at the minimum boom angle.

Once these angles are exceeded, the red warning light will come on and the horn will sound. Horn and warning light are overlooked at a less than O0 position of the left knob.

4. PANEL (B 50)

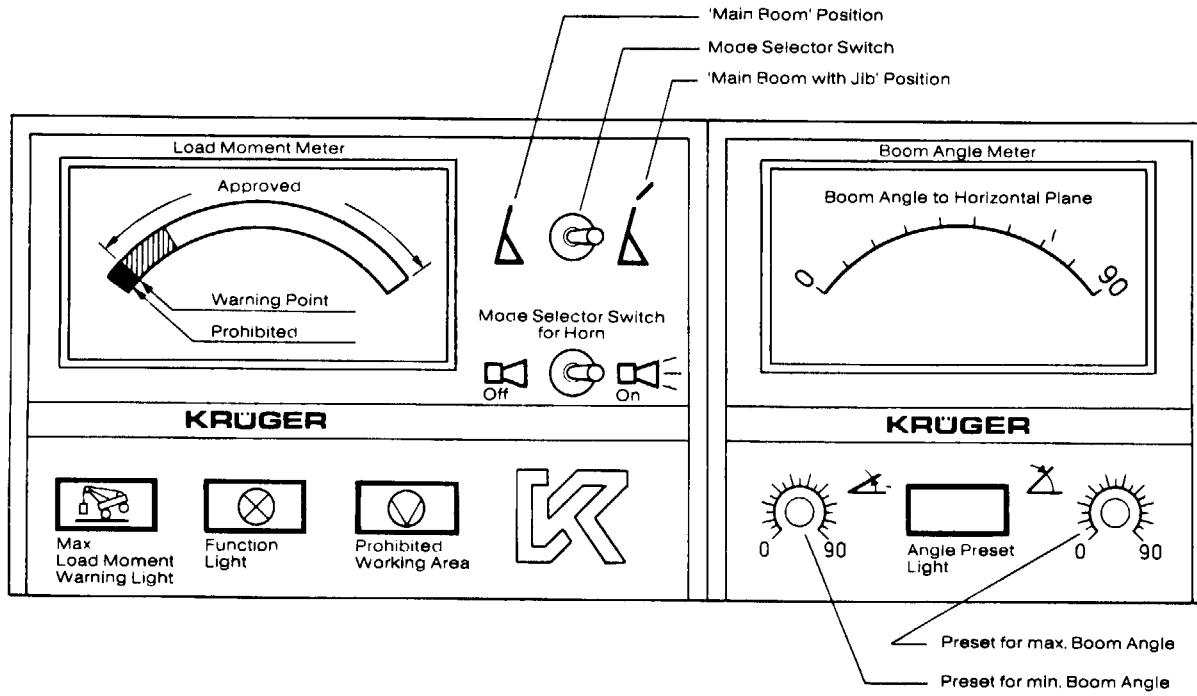

5.WORKING INSTRUCTIONS

This Load Moment Device is made to fit the crane it is installed. Therefore, all instructions imposed by the crane Manufacturer have to be observed.

1. Place Mode Selector Switch to left hand position before starting engine.

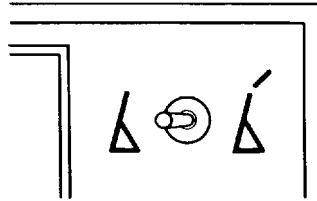

Horn switch must be turned on when operating crane, however, horn switch may be turned off when boom is in stowed position.

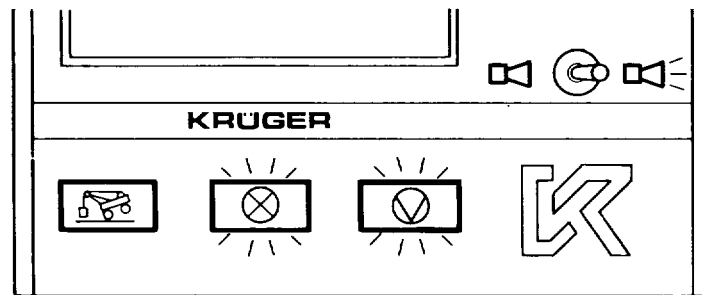

2. Start engine

Function light and prohibited working area alarm light should come on. Load moment indicator needle should be in operating range.

3. Prohibited working area alarm light should go out as crane swings into approved working area.

- Place Mode Selector Switch to actual boom configuration.

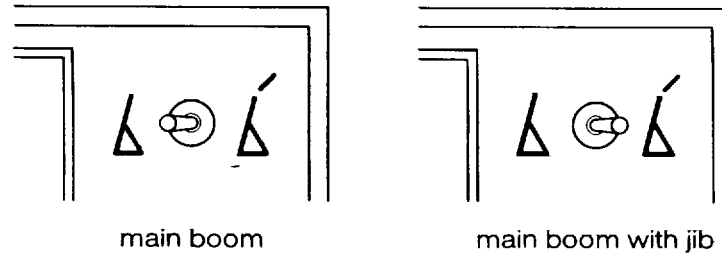

IMPORTANT !

THE CORRECT SWITCH POSITION MUST BE SELECTED BY THE OPERATOR OR A POSSIBLE INCORRECT RATING CONDITION WILL RESULT.

- Set angle preset to requested boom angle working area.

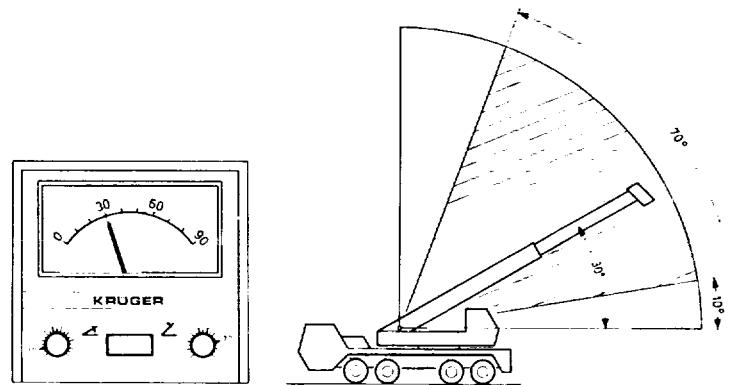

Sample

Once settled angles are exceeded, the middle red warning light will come on and the horn will sound.

- With correct register from panel, crane is ready to operate.

Operate crane in a normal manner, at all times staying within load chart limitations.

7. Returning Boom to Stowed Position

- Return boom to stowing configuration (boom fully retracted)

- Raise boom and swing to front; lower boom to rest in cradle

- Prohibited working area alarm light should come on as crane swings out of permissible working area

- Shut down crane; return mode selector switch to left hand position.

All lights should be out.

6. REACHING MAXIMUM ALLOWABLE LOAD MOMENT

The line between the red and yellow zone at the load-moment meter represents 100 % of allowable load moment. If the crane reaches this limit, the Krueger load moment indicator will indicate this condition by:

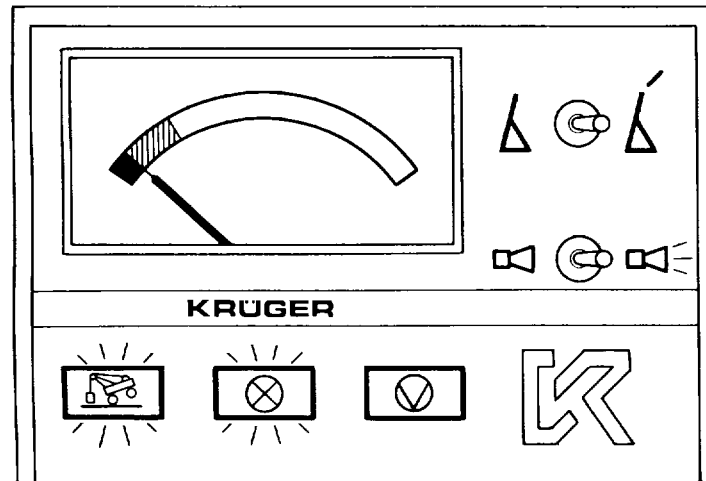

- LOAD MOMENT ALARM LIGHT - ON
- LOAD MOMENT INDICATOR NEEDLE ON LINE BETWEEN RED AND YELLOW AREA
- HORN WILL SOUND

The load moment must now be reduced by retracting or elevating boom until load moment indicator needle is in operating range.

Alarm light should go out indicating system is again ready for operating.

7. ENTERING PROHIBITED WORKING AREA

The prohibited working area alarm light will come on and the horn will sound at any time the crane swings out of the permissible working area.

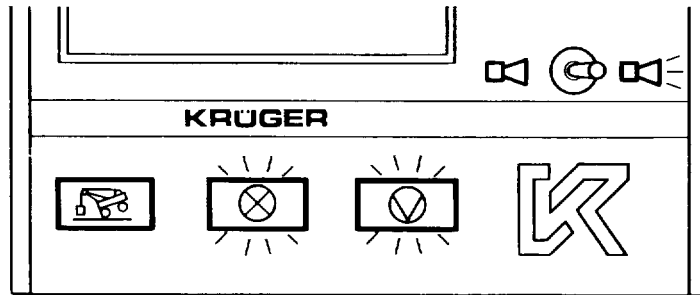

To correct this condition, swing superstructure into permissible working area.

The prohibited working range alarm light should go out and horn should stop.

8. LIGHT FLASH ON THE PANEL AND ITS CAUSE

1. Load Moment Warning Light comes on:
Maximum allowable Load Moment is being reached.
- Retract or elevate boom until Load Moment Indicator needle is in operating range.
2. Function Light comes on:
System is powered by crane battery
If light does not come on, check power supply to the Electronic (B 10) and afterwards fuse inside of Electronic (B 10).
3. Prohibited Working Area Light comes on:
Superstructure of crane has swung into forbidden working area.
- Swing superstructure into permissible working area.
4. Angle Preset Light comes on:
Settled boom angles have been exceeded.
- Correct by derricking boom into settled boom angle area.

9. PREVENTIVE MAINTENANCE

There are electrical, mechanical and electronic sections included in the Krueger Load Moment System. The Electronic section is solid state and modular design. It should only be serviced by authorized specialists.

The Operator himself should accept some responsibility beyond just "operating". He should make a daily walkaround inspection of the crane. This inspection would include a check of the System. He should be alert for any evidence of vandalism and damage before starting the crane. This Daily Inspection for damage should start at the boom and include the following:

- Check entire length of boom length sensor rope.
- Check spring-loaded cable reel. Make sure it has spring tension and is free to rotate. Too much slack in rope can cause a misleading transmission of boom length correction signal to the bridge amplifier circuit unit.
- Check Hydraulic Electronic.
- Check cab panel.
- Check roller switches between superstructure and chassis.

1000 Hours and/or Annual Inspection:

It is recommended that the system be inspected for accuracy at 1000 hours or annually which ever occurs first, or if it is believed that the system has been damaged or there is proof of malfunction.

For calibration procedue, consult only authorized specialists.

For cranes in storage all functions of the control panel should be tested every three months by using test weights.

This page intentionally left blank,

APPENDIX A

Operator/Crew Preventive Maintenance Checks and Services

NOTE: Within designated Interval, these checks are to be performed In the order listed.

B-Before
D-During

W-Weekly

A-After **M**-Monthly
C-Combat Operability Check

TM5

Table 2-2.

ITEM NO	INTERVAL					C	Items to be Inspected	Procedures. Check for and have repaired or adjusted as necessary	Equipment will be reported Not Ready if:
	B	D	A	W	M				
1		X		X			Engine Oil	Lubricate in accordance with current lubrication order Check for proper oil level Grove LO, Service Manual, Page 5-1/5-9 unserviceable (less than	1. One or more urgent MWOs not applied. 2. Tires. Three or more tires missing, flat and/or
2		X			X		Generator & Fan Belts	Check for proper adjustments Service Manual; Page 4-80.	1/4 in tread depth).
3	X	X					Engine Coolant levels	3. Engine. Excessive Check for proper coolant Page 4-77	noise or vibration, inoperative or not operating properly.
4	X	X					Engine Fuel Tank	Check fuel level, Page 4-84.	
5				X		X	Batteries	more missing or will not Check electrolyte level freezing weather run engine- for a minimum of 1 hour after adding water. Check for tightness of connections. Service Manual, Page 4-359.	4. Batteries. -One or In crank engine.
6	X	X		X			Air Cleaners	Service air filter every 500 hours or as indicated by the service manual Manual, Grove Mfg Page 4-74	5. Transmission. Excessive noise, leaking more than 3 drops in 5 minutes or visible cracks. 6. Frame & Wheels. Broken welds or cracks. Service
7			X				All Control	Check operating mechanisms for maladjustments, excessive wear, or contamination by leaking lubricants or foreign material TB 43-0142, Page A-1, Appendix A.	7. Hydraulic System and Power Controls. Not operating properly. Excessive noise, vibration, visible cracks or leaking more than 3 drops in 5 minutes. Item 1 -

APPENDIX A

Operator/Crew Preventive Maintenance Checks and Services

NOTE Within designated Interval these checks are to be performed In the order listed.

ITEM NO	B-Before D-During					C	Items to be Inspected	Procedures. Check for and have repaired or adjusted as necessary	Equipment will be reported Not Ready if:
	B	D	A	W	M				
14					X	X	Universal joints & Drive Shafts	Loose nuts, clamps, worn bearing. Grove Service Manual, Page 4-302	TB 43-0142,
			15		X	X	Super Structure	Cracks, loose bolts, and nuts. Grove Service Manual Section 3	
16		X				X	Boom Assy	Metal cracks, bent or warps, loose bolts, oper3ble weights. TB 43-0142, Appendix A, Page A-1	
17				X			Lift Cyl	Leaks, scored, nicks, dents, loose or deformed rod eyes TB 43-0142, Page A-2, Appendix A..	
18				X			Hydraulic Hoses, Fitting & Tubing	Leaks, any blistering or abnormal deformation of hoses. TB 43-0142, Page A-2, Appendix A	
19					X		Load Boom Angle Indi-	For any significant Inaccuracies (13') Appendix A, Page A-1.	
20	X	X			X		Steering, Brakes, Locking & Travel Devices	For malfunction. TB 13-0142, Page A-1, Appendix A.	

APPENDIX A

Operator/Crew Preventive Maintenance Checks and Services

NOTE Within designated Interval these checks are to be performed In the order listed

**B-Before
D-During**

**A-After
W-Weekly**

**M-Monthly
C-Combat Operability Check**

ITEM NO	INTERVAL					C	Items to be Inspected	Procedures. Check for and have repaired or adjusted as necessary	Equipment will be reported Not Ready if:
	B	D	A	W	M				
21			X		X		Electrical Components	For signs of pitting of any deterioration of controller contactors, limit switches & pushbutton stations. TB 43-0142, Appendix A, Page A-1.	
22					X		Drums, Sheaves, Pulley & Hoists	Smoothness & freedom from surface defects, sheaves pitch diameters, eccentric bores, cracked hubs, spokes and flanges. TB 43-0142, Appendix A, Page A-1.	
23	X		X				Air or hyd system	For deterioration or leakage. TB 43-0142, Appendix A, Page A-1.	
24	X	X					Electrical	Lights (signal & running), horn, windshield wipers & washers for proper operation.	
25	X	X					Clutch free travel	Check for proper clutch Grove Service Manual, Page 4-226	
26	X	X					Tires	Check for damage and proper inflation. As indicated on tire.	

APPENDIX A

Operator/Crew Preventive Maintenance Checks and Services

NOTE Within designated Interval these checks are to be performed In the order listed.

**B-Before
D-During**

**A-After
W-Weekly**

**M-Monthly
C-Combat Operability Check**

ITEM NO	INTERVAL					C	Items to be Inspected	Procedures. Check for and have repaired or adjusted as necessary	Equipment will be reported Not Ready if:
	B	D	A	W	M				
27	X	X					Hydraulic Reservoir & Filter	Check fluid level, filter condition indicator for proper indications and breather for cleanliness & security. Grove Service Manual, Page 3-31 and 3-33	
28		X					Gages	Check for proper indications after engine start of air, oil, voltmeter & temperature gages. Carrier operators Handbook, Pages 26 & 27	

A-5/A-6 Blank

APPENDIX B

MAINTENANCE AND OPERATING SUPPLY LIST (CCE)

NOMENCLATURE: Crane, Truck Mounted, Hydraulic 25 Ton (CCE)		MAKE: Grove Mfg Company		MODEL: TMS 300-5	
MFR PART NO:		NSN: 3810-01-054-9779		SERIAL NO. RANGE: _____ TO _____	
DATE: Jan 78					
(1) COMPONENT APPLICATION	(2) MFR PART NO. OR NAT'L STOCK NO.	(3) DESCRIPTION	(4) QTY REQ F/INITIAL OPN	(5) QTY REQ F/8 HRS OPN	(6) NOTES
ENGINE		No. 2-D Diesel Fuel	90 gal	55 gal	
COOLANT		50% Ethylene Glycol, 50% water	54 qt		
ENGINE	9150-188-9858	ENGINE OIL MIL-L-2104C OE/HDO 30 - 5 gallons	21 qt		Add 2 qt for filter.
	9150-242-7603	MIL-E-46167 OEA - 5 Gallons			Arctic for below - 20 ^o F
TRANSMISSION, MAIN	9150-754-2635	GEAR OIL MIL-L-2105C GO-90 - 1 Qt	8 qt		Summer
	9150-905-9100	MIL-L-2105C GO-80 - 1 Gal			Winter
FRONT REAR AXLE	9150-754-2635	GEAR OIL MIL-L-2105C GO-90 - 1 Qt	37 Pints		Summer
	9150-905-9100	MIL-L-2105C GO-80 - 1 Gal			Winter

MAINTENANCE AND OPERATING SUPPLY LIST (CCE)

(1) COMPONENT APPLICATION		(2) MFR PART NO. OR NAT'L STOCK NO.	(3) DESCRIPTION	(4) QTY REQ F/INITIAL OPN	(5) QTY REQ F/8 HRS OPN	(6) NOTES
REAR REAR AXLE		9150-754-2635	GEAR OIL MIL-L-2105C GO-90 - 1 Qt	36 Pints		Summer
		9150-905-9100	MIL-L-2105C GO-80 - 1 Gal			Winter
STEERING GEAR		9150-265-9425	HYDRAULIC OIL MIL-L-2104C OE/HDO 10 - 1 Qt	8 Qt		Arctic Conditions
		9150-242-7603	MIL-L-46167 OEA - 5 Gal			
		9150-00-577-5844	MIL-L-2105C			
		9150-985-7231	LUBE OIL - 5 Gal MIL-L-17672B 2075 TH - 1 Qt	4 Qt		

NOMENCLATURE: Crane, Truck Mounted, Hydraulic,
25 Ton (CCE)

MAKE: Grove Mfg Company

MODEL:

MFR PART NO:

NSN:

SERIAL NO. RANGE:
TO

DATE: Jan 78

APPENDIX B

MAINTENANCE AND OPERATING SUPPLY LIST (CCE)

NOMENCLATURE: Crane, Truck Mounted, Hydraulic, 25 Ton (CCE)		MAKE: Grove Mfg Company		MODEL:	
MFR PART NO:		NSN:		SERIAL NO. RANGE: TO	
				DATE: Jan 78	
(1) COMPONENT APPLICATION	(2) MFR PART NO. OR NAT'L STOCK NO.	(3) DESCRIPTION	(4) QTY REQ F/INITIAL OPN	(5) QTY REQ F/8 HRS OPN	(6) NOTES
HYDRAULIC SYSTEM	9150-265-9429 9150-242-7603 9150-985-7233	HYDRAULIC OIL MIL-L-2104C OE/HDO 10 - 55 Gal MIL-L-46167 OEA - 5 Gal MIL-L-17672B 2075 TH - 55 Gal	127 Gal		Fill to full mark with Crane in travel mode.
SWING BRAKE MASTER CYLINDER	9150-00-190-0932	BRAKE FLUID, AUTOMOTIVE VV-B-680	1 Pint		
LUBRICATION POINTS	9150-00-190-0905	GAA GREASE MIL-G-10924	As Req		
OPEN GEAR LUBE	9150-00-234-5197	LUBRICANT CW-11 VV-L-751	As Req		

By Order of the Secretary of the Army:

Official:

J. C. PENNINGTON

Major General, United States Army
The Adjutant General

E. C. MEYER

*General, United States Army
Chief of Staff*

DISTRIBUTION:

To be distributed in accordance with DA Form 12-25B, Operator maintenance requirements for Cranes, Truck Mounted.

* GPO - 1993 0 - 342-421 (80032)

RECOMMENDED CHANGES TO EQUIPMENT TECHNICAL PUBLICATIONS



THEN... JOT DOWN THE DOPE ABOUT IT ON THIS FORM, CAREFULLY TEAR IT OUT, FOLD IT AND DROP IT IN THE MAIL!

SOMETHING WRONG WITH THIS PUBLICATION?

FROM: (PRINT YOUR UNIT'S COMPLETE ADDRESS)

DATE SENT

PUBLICATION NUMBER

PUBLICATION DATE

PUBLICATION TITLE

BE EXACT... PIN-POINT WHERE IT IS

PAGE NO.

PARA-GRAPH

FIGURE NO.

TABLE NO.

IN THIS SPACE TELL WHAT IS WRONG AND WHAT SHOULD BE DONE ABOUT IT:

TEAR ALONG PERFORATED LINE

PRINTED NAME, GRADE OR TITLE, AND TELEPHONE NUMBER

SIGN HERE:

DA FORM 2028-2
1 JUL 79

PREVIOUS EDITIONS ARE OBSOLETE.

P.S.—IF YOUR OUTFIT WANTS TO KNOW ABOUT YOUR RECOMMENDATION MAKE A CARBON COPY OF THIS AND GIVE IT TO YOUR HEADQUARTERS.

THE METRIC SYSTEM AND EQUIVALENTS

LINEAR MEASURE

- 1 Centimeter = 10 Millimeters = 0.01 Meters = 0.3937 Inches
- 1 Meter = 100 Centimeters = 1.000 Millimeters = 39.37 Inches
- 1 Kilometer = 1.000 Meters = 0.621 Miles

SQUARE MEASURE

- 1 Sq Centimeter = 100 Sq Millimeters = 0.155 Sq Inches
- 1 Sq Meter = 10,000 Sq Centimeters = 10.76 Sq Feet
- 1 Sq Kilometer = 1,000,000 Sq Meters = 0.386 Sq Miles

CUBIC MEASURE

- 1 Cu Centimeter = 1,000 Cu Millimeters = 0.06 Cu Inches
- 1 Cu Meter = 1,000,000 Cu Centimeters = 35.31 Cu Feet

LIQUID MEASURE

- 1 Milliliter = 0.001 Liters = 0.0338 Fluid Ounces
- 1 Liter = 1,000 Milliliters = 33.82 Fluid Ounces

TEMPERATURE

- $5/9 (^{\circ}\text{F} - 32) = ^{\circ}\text{C}$
- 212° Fahrenheit is equivalent to 100° Celsius
- 90° Fahrenheit is equivalent to 32.2° Celsius
- 32° Fahrenheit is equivalent to 0° Celsius
- $9/5 \text{ C}^{\circ} + 32 = \text{F}^{\circ}$

WEIGHTS

- 1 Gram = 0.001 Kilograms = 1,000 Milligrams = 0.035 Ounces
- 1 Kilogram = 1,000 Grams = 2.2 lb.
- 1 Metric Ton = 1,000 Kilograms = 1 Megagram = 1.1 Short Tons

APPROXIMATE CONVERSION FACTORS

TO CHANGE	TO	MULTIPLY BY
Inches	Centimeters	2.540
Feet	Meters	0.305
Yards	Meters	0.914
Miles	Kilometers	1.609
Square Inches	Square Centimeters	6.451
Square Feet	Square Meters	0.093
Square Yards	Square Meters	0.836
Square Miles	Square Kilometers	2.590
Acres	Square Hectometers	0.405
Cubic Feet	Cubic Meters	0.028
Cubic Yards	Cubic Meters	0.765
Fluid Ounces	Milliliters	29.573
Pints	Liters	0.473
Quarts	Liters	0.946
Gallons	Liters	3.785
Ounces	Grams	28.349
Pounds	Kilograms	0.454
Short Tons	Metric Tons	0.907
Pound-Feet	Newton-Meters	1.356
Pounds Per Square Inch	Kilopascals	6.895
Miles Per Gallon	Kilometers Per Liter	0.425
Miles Per Hour	Kilometers Per Hour	1.609
TO CHANGE	TO	MULTIPLY BY
Centimeters	Inches	0.394
Meters	Feet	3.280
Meters	Yards	1.094
Kilometers	Miles	0.621
Square Centimeters	Square Inches	0.155
Square Meters	Square Feet	10.764
Square Meters	Square Yards	1.196
Square Kilometers	Square Miles	0.386
Square Hectometers	Acres	2.471
Cubic Meters	Cubic Feet	35.315
Cubic Meters	Cubic Yards	1.308
Milliliters	Fluid Ounces	0.034
Liters	Pints	2.113
Liters	Quarts	1.057
Liters	Gallons	0.264
Grams	Ounces	0.035
Kilograms	Pounds	2.205
Metric Tons	Short Tons	1.102
Newton-Meters	Pound-Feet	0.738
Kilopascals	Pounds Per Square Inch	0.145
Kilometers Per Liter	Miles Per Gallon	2.354
Kilometers Per Hour	Miles Per Hour	0.621

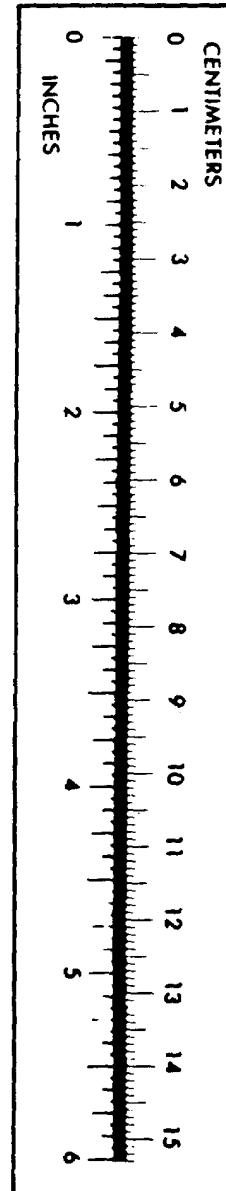

PIN: 045412-000